

**TECHNICAL MANUAL**  
**OPERATOR, ORGANIZATIONAL, DIRECT AND GENERAL**  
**SUPPORT MAINTENANCE MANUAL**  
**COMPRESSOR, RECIPROCATING, AIR**  
**WHEEL MOUNTED, 2 WHEEL**  
**PNEUMATIC TIRES: GED, 4 CFM, 3000 PSI**  
**(210.9000 KGS PER SQ CM)**  
**(WALTER KIDDE MODEL 893811)**  
**NSN 4310-00.997-6004**

---

**HEADQUARTERS, DEPARTMENT OF THE ARMY**  
**JUNE 1975**



**OPERATOR, ORGANIZATIONAL, DIRECT AND GENERAL  
SUPPORT MAINTENANCE MANUAL  
COMPRESSOR, RECIPROCATING, AIR  
WHEEL MOUNTED, 2 WHEEL  
PNEUMATIC TIRES: GED, 4 CFM, 3000 PSI  
(210.9000 KGS PER SQ CM)  
(WALTER KIDDE MODEL 893811)  
NSN 4310-00-997-6004**

			<i>Paragraph</i>	<i>Page</i>
CHAPTER	1.	INTRODUCTION		
Section	I.	General		
		Scope .....	1-1	1-1
		Maintenance Forms and Records.....	1-2	1-1
		Reporting of Errors.....	1-3	1-1
		Destruction of Army Material to Prevent Enemy Use...	1-4	1-1
		Administrative Storage.....	1-5	1-1
	II.	Description and Data		
		Description.....	1-6	1-1
		Differences in Models .....	1-7	1-3
		Tabulated Data .....	1-8	1-3
CHAPTER	2.	OPERATING INSTRUCTIONS		
Section	I.	Operating Procedures		
		General.....	2-1	2-1
		Controls .....	2-2	2-1
		Instruments.....	2-3	2-1
	II.	Operation of Auxiliary Equipment		
		General.....	2-4	2-4
		Operation.....	2-2	2-4
	III.	Operation Under Usual Conditions		
		General.....	2-6	2-4
		Starting Engine .....	2-7	2-4
		Operation.....	2-8	2-4
		Stopping Engine.....	2-9	2-5
	IV.	Operation Under Unusual Conditions		
		General.....	2-10	2-5
		Operation in Extreme Cold.....	2-11	2-5
		Operation Under Sandy or Dusty Conditions.....	2-12	2-6
		Operation in Salt Water Areas .....	2-13	2-6
		Operation at High Altitude.....	2-14	2-6
		Operation in Extreme Heat.....	2-15	2-6

---

\*This manual supersedes TM 5-4310-335-15, 4 June 1969, including all changes.

CHAPTER	3.	OPERATOR'S MAINTENANCE INSTRUCTIONS		
Section	I.	Lubrication Instructions		
		General Lubrication Information.....	3-1	3-1
		Detailed Lubrication Information.....	3-2	3-1
	II.	Preventive Maintenance Checks and Services		
		General.....	3-3	3-1
		Preventive Maintenance Checks and Services.....	3-4	3-1
	III.	Troubleshooting		
		General.....	3-5	3-1
		Operator Maintenance Troubleshooting.....	3-6	3-1
CHAPTER	4.	ORGANIZATIONAL MAINTENANCE INSTRUCTIONS		
Section	I.	Service Upon Receipt of Equipment		
		Inspecting and Servicing the Equipment .....	4-1	4-1
	II.	Repair Parts, Special Tools and Equipment.		
		Tools and Equipment .....	4-2	4-1
		Special Tools and Equipment.....	4-3	4-1
		Maintenance Repair Part.....	4-4	4-1
	III.	Preventive Maintenance Checks and Services		
		General.....	4-5	4-1
		Preventive Maintenance Checks and Services.....	4-6	4-1
	IV.	Troubleshooting		
		General.....	4-7	4-3
		Organizational Maintenance Troubleshooting.....	4-8	4-3
	V.	Radio Interference Suppression		
		Definitions.....	4-9	4-7
		General Methods Used to Attain Proper Suppression ..	4-10	4-7
		Interference Suppression Components.....	4-11	4-8
		Replacement of Suppression Components.....	4-12	4-8
		Testing of Radio Interference Suppression Components	4-13	4-8
	VI.	Maintenance of Fuel Tank		
		Fuel Tank.....	4-14	4-8
	VII.	Maintenance of Pneumatic System Accessories		
		Dehydrator Cartridge.....	4-15	4-8
		Moisture Separator and Sphere Safety Cap Tape .....	4-16	4-9
		Sphere Pads .....	4-17	4-9
		Service Accessories.....	4-18	4-9
	VIII.	Maintenance of Compressor/Cooler Assembly		
		Air Compressor Inlet Air Filter .....	4-19	4-10
		Dipstick and Oil Strainer .....	4-20	4-10
	IX.	Maintenance of Axles, Brakes, and Wheels		
		Wheel and Hub Assembly .....	4-21	4-11
		Axle Assembly .....	4-22	4-11
		Brakes Assembly .....	4-23	4-13
CHAPTER	5.	DIRECT SUPPORT AND GENERAL SUPPORT MAINTENANCE INSTRUCTIONS		
Section	I.	Repair Parts, Special Tools and Equipment		
		Tools and Equipment .....	5-1	5-1
		Special Tools and Equipment.....	5-2	5-1
		Maintenance Repair Parts.....	5-3	5-1
	II.	Troubleshooting		
		General.....	5-4	5-1
		Direct Support and General Support Troubleshooting..	5-5	5-1
	III.	General Maintenance		
		General.....	5-6	5-8
		Repair and Replacement Standards.....	5-7	5-8
	IV.	Removal and Installation of Major Components and Assemblies		
		Roof Assembly.....	5-8	5-9
		Dehydrator .....	5-9	5-9
		Moisture Separator and Sphere.....	5-10	5-11
		Engine Assembly .....	5-11	5-14
		Compressor/Cooler .....	5-12	5-20

CHAPTER	6.	REPAIR OF ROOF ASSEMBLY AND PNEUMATIC SYSTEM ACCESSORIES		
Section	I.	Roof Assemblies		
		Roof Assemblies and Components.....	6-1	6-1
	II.	Pneumatic System Accessories		
		Dehydrator Assembly.....	6-2	6-10
		Moisture Separator Assembly .....	6-3	6-10
		Sphere Assembly.....	6-4	6-14
		Valve Assemblies and Timer Box Assembly .....	6-5	6-15
CHAPTER	7.	REPAIR OF COMPRESSOR/COOLER ASSEMBLY AND FRAME		
Section	I.	Compressor/Cooler Assembly		
		Compressor/Cooler Assembly.....	7-1	7-1
	II.	Frame Assembly		
		Frame.....	7-2	7-9
APPENDIX	A.	REFERENCES.....		A-1
	B.	MAINTENANCE ALLOCATION CHART.....		B-1
	C.	BASIC ISSUE ITEM LIST AND ITEMS TROOP INSTALLED OR AUTHORIZED (Not Applicable)		

**LIST OF ILLUSTRATIONS**

<i>Figure</i>	<i>Title</i>	<i>Page</i>
1-1.	Air Compressor .....	1-2
2-1.	Air Compressor, Right Hand View .....	2-2
2-2.	Air Compressor, Three- Quarter Rear View .....	2-3
3-1.	Compressor Lubrication Chart.....	3-2-3-3
4-1.	Inlet Air Filter and Dipstick .....	4-10
4-2.	Tire Wheel and Hub Assembly .....	4-12
4-3.	Axle Assembly .....	4-13
4-4.	Brake Assembly .....	4-14
5-1.	Roof Assembly .....	5-10
5-2.	Dehydrator .....	5-11
5-3.	Moisture Separator.....	5-12
5-4.	Sphere .....	5-13
5-5.	Air Compressor .....	5-15
5-6.	Engine and Compressor Assembly.....	5-16
6-1.	Roof Assembly.....	6-2-6-4
6-2.	Fuel Tank Assembly.....	6-6
6-3.	Charging Chuck Assembly .....	6-7
6-4.	Heater Cable Assembly.....	6-8
6-5.	Dehydrator Assembly .....	6-11
6-6.	Moisture Separator Assembly.....	6-13
6-7.	Sphere Assembly Components .....	6-15
6-8.	Sphere Relief Valve .....	6-16
6-9.	Back Pressure Valve Assembly.....	6-17
6-10.	Check Valve Assembly .....	6-18
6-11.	Timer Box Assembly .....	6-19
6-12.	Unloader Valve Assembly .....	6-20
6-13.	Timer Box Control Valve Setting Setup .....	6-22
6-14.	Unloader Valve Setting and Testing Setup .....	6-23
7-1.	Intercoolers, Fan and Lubrication Lines .....	7-2
7-2.	Oil Lines and Mounting Hardware.....	7-3
7-3.	First Stage Relief Valve .....	7-4
7-4.	Second Stage Relief Valve .....	7-4
7-5.	Third Stage Relief Valve .....	7-5
7-6.	Aftercooler, Relief Lines and Mounting Hardware.....	7-6
7-7.	Fourth Stage Relief Valve .....	7-7
7-8.	Frame Assembly .....	7-10

**LIST OF TABLES**

<i>Number</i>	<i>Title</i>	<i>Page</i>
3-1.	Preventive Maintenance Checks and Services.....	3-4
3-2.	Troubleshooting .....	3-5
4-1.	Organizational Preventive Maintenance Checks and Services .....	4-2
4-2.	Troubleshooting .....	4-3
5-1.	Troubleshooting .....	5-1
5-2.	Recommended Wrench Torques and Tolerances.....	5-9

## CHAPTER 1 INTRODUCTION

---

### Section I. GENERAL

#### 1-1. Scope

This manual is for your use in operating and maintaining the Air Compressor, Model No. 893811, manufactured by Walter Kidde & Company, Inc., Belleville, New Jersey. The publication contains maintenance information for operator, organizational, direct support and general support maintenance personnel.

#### 1-2. Maintenance Forms and Records

- a. DA Form 2404 (Equipment Inspection and Maintenance Worksheet).
- b. DA Form 2407 (Maintenance Request Used for Requesting Support Maintenance).
- c. DA Form 2407-1 (Continuation Sheet Used for Requesting Support Maintenance).
- d. For further information refer to TM 38-750

(The Army Maintenance Management System (TAMMS)).

#### 1-3. Reporting of Errors

You can help to improve this manual by calling attention to errors and recommending improvements. Your letter, DA Form 2028 (Recommended Changes to Publications), and/or DA Form 2028-2 (Recommended Changes to Equipment Technical Manuals), may be used. Copies of DA Form 2028-2 are attached in the back of the manual for your use. Please mail your recommended changes directly to Commander, U.S. Army Troop Support Command, ATTN: AMST-MPP, 4300 Goodfellow Blvd., St. Louis, Mo. 63120. A reply will be furnished directly to you.

#### 1-4. Destruction of Army Material to Prevent Enemy Use

a. Place as many of the following charges as the situation permits and detonate them simultaneously with detonating cord and suitable detonator.

- (1) One 1/2-pound (.22 kg) charge between the compressor and the air receiver tank.

#### NOTE

The above step is a minimum requirement for this method.

- (2) One 1/2-pound (.22 kg) charge between the engine or motor and the air receiver tank.

b. For further information refer to TM 750-244-3 (Procedures for Destruction of Equipment to Prevent Enemy Use.).

#### 1-5. Administrative Storage

a. Store equipment so as to provide maximum protection from the elements and to provide access for inspection, maintenance, and exercising. Anticipate removal or deployment problems and take suitable precautions.

b. Take into account environmental conditions, such as, extreme heat or cold; high humidity; blowing sand, dust, or loose debris; soft ground; mud; heavy snows; earthquakes; or combinations thereof and take adequate precautions.

c. Establish a fire plan and provide adequate firefighting equipment and personnel.

d. For further information refer to TM 740-90-1 (Administrative Storage of Equipment).

### Section II. DESCRIPTION AND DATA

#### 1-6. Description

a. *General.* The air compressor delivers 4.0 scfm compressed air at a delivery pressure of 3000 psig (210.9000 kgs per sq cm) for pneumatic pressure application. The air compressor is completely self-contained and consists of a two-cylinder, four-cycle gasoline engine drive, a four-stage, reciprocating, radial air compressor, all the necessary accessory components required for operation, protection and transportation of the unit. The air compressor consists of the following groups, see figure 1-1.

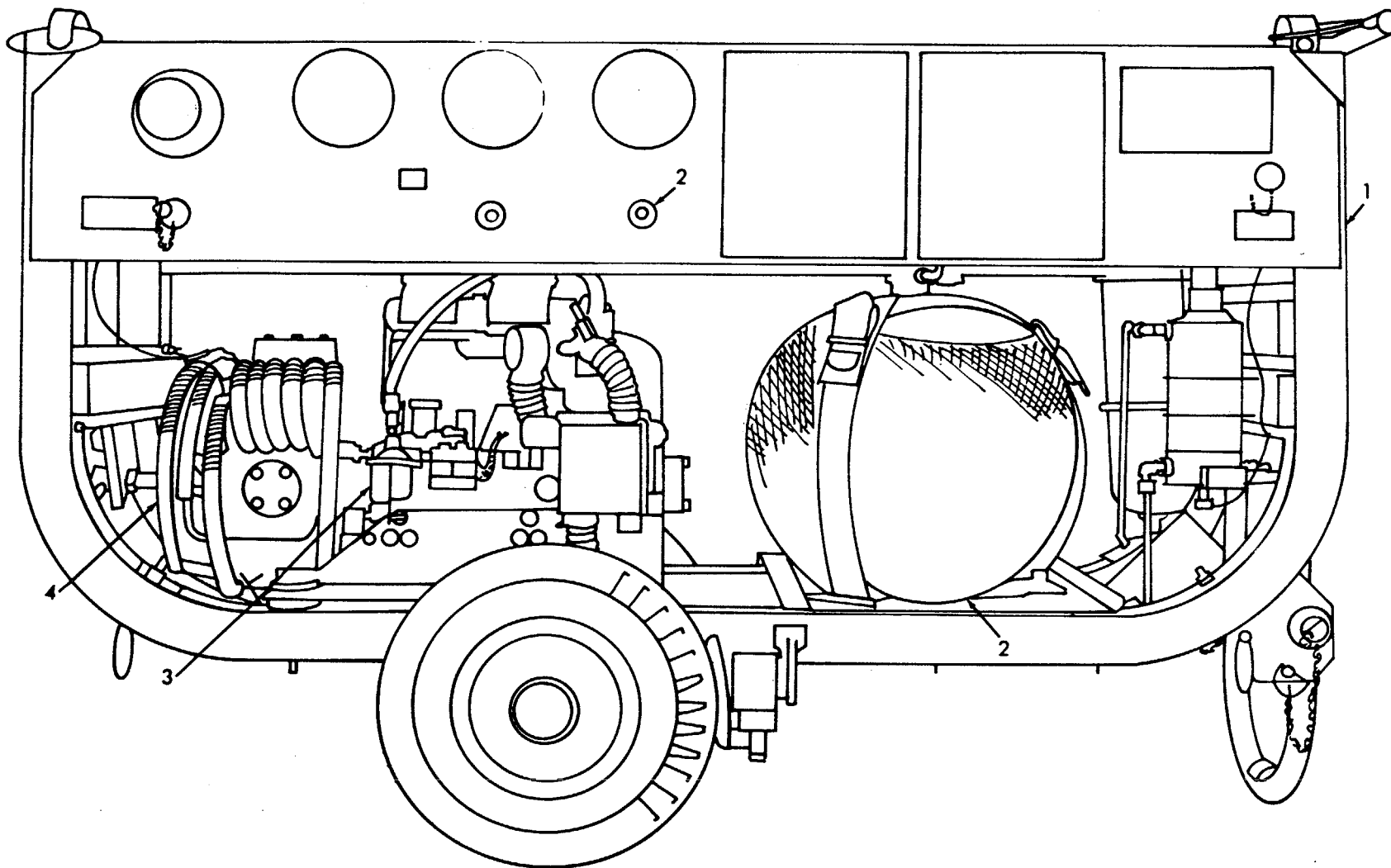

TS014501

- 1. Frame ay
- 2. Pneumatic accessories

- 3. Gasoline engine
- 4. Compressor/cooler ay

Figure 1-1. Air Compressor  
1-2