

VOLUME NO. 1
DIRECT SUPPORT

TECHNICAL MANUAL
DIRECT SUPPORT AND
GENERAL SUPPORT MAINTENANCE

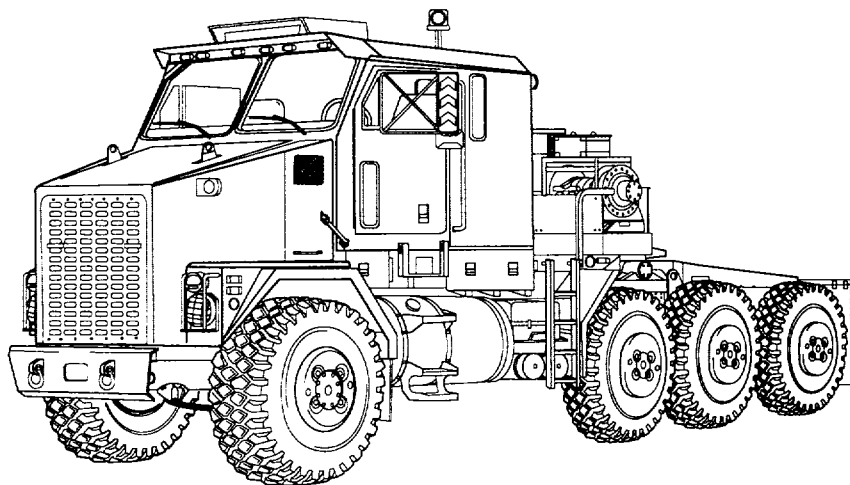

TRUCK, TRACTOR, M1070, 8 X 8,
MAINTENANCE
HEAVY EQUIPMENT TRANSPORTER (HET)
NSN 2320-01-318-9902
EIC: B5C

HOW TO USE THIS MANUAL	VI
TROUBLESHOOTING	2-2
ENGINE MAINTENANCE	3-1
FUEL SYSTEM MAINTENANCE	4-1
COOLING SYSTEM MAINTENANCE	5-1
ELECTRICAL SYSTEM MAINTENANCE	6-1
TRANSMISSION MAINTENANCE	7-1
BRAKE SYSTEM MAINTENANCE	11-1
STEERING SYSTEM MAINTENANCE	13-1
FRAME MAINTENANCE	14-1
CAB AND BODY	16-1
WINCHES MAINTENANCE	17-1
SUBJECT INDEX	INDEX-1

Approved for public release; distribution is unlimited.

HEADQUARTERS, DEPARTMENT OF THE ARMY

MARCH 1994

DIRECT SUPPORT AND GENERAL SUPPORT MAINTENANCE MANUAL

**TRUCK, TRACTOR, M1070, 8 X 8,
HEAVY EQUIPMENT TRANSPORTER (HET)
(NSN 2320-01-318-9902)
EIC: B5C**

REPORTING ERRORS AND RECOMMENDING IMPROVEMENTS

You can help improve this manual. If you find any mistakes or if you know of a way to improve the procedures, please let us know. Mail your letter, DA Form 2028 (Recommended Changes to Publications and Blank Forms), or DA Form 2028-2 located in the back of this manual direct to: Commander, U.S. Army Tank-Automotive and Armaments Command, ATTN: AMSTA-IM-OPIT, Warren, MI 48397-5000. A reply will be furnished to you.

TABLE OF CONTENTS

DIRECT SUPPORT MAINTENANCE

		Page
	<u>HOW TO USE THIS MANUAL</u>	v
CHAPTER 1	INTRODUCTION	
Section I	General Information	1-1
Section II	Equipment Description and Data	1-3
Section III	Principles of Operation	1-4
CHAPTER 2	VEHICLE MAINTENANCE	
Section I	Repair Parts; Special Tools; Test, Measurement, and Diagnostic Equipment (TMDE); and Support Equipment	2-1
Section II	<u>Troubleshooting</u>	2-2
Section III	Maintenance Procedures	2-184
Section IV	Preparation for Storage or Shipment	2-192
Section V	Pre-Embarkation Inspection of Materiel in Units Alerted for Overseas Movement	2-193
CHAPTER 3	<u>ENGINE MAINTENANCE</u>	3-1
Section I	Introduction	3-1
Section II	Service Upon Receipt	3-2
Section III	Maintenance Procedures	3-2

TABLE OF CONTENTS (CONT)

		Page
CHAPTER 4	FUEL SYSTEM MAINTENANCE	
Section I	Introduction	4-1
Section II	Maintenance Procedures	4-1
CHAPTER 5	COOLING SYSTEM MAINTENANCE	
Section I	Introduction	5-1
Section II	Maintenance Procedures	5-1
CHAPTER 6	ELECTRICAL SYSTEM MAINTENANCE	
Section I	Introduction	6-1
Section II	Maintenance Procedures	6-1
CHAPTER 7	TRANSMISSION MAINTENANCE	
Section I	Introduction	7-1
Section II	Service and Inspection	7-1
Section III	Maintenance Procedures	7-2
CHAPTER 8	TRANSFER CASE MAINTENANCE	
Section I	Introduction	8-1
Section II	Maintenance Procedures	8-1
CHAPTER 9	FRONT AXLE MAINTENANCE	
Section I	Introduction	9-1
Section II	Maintenance Procedures	9-1
CHAPTER 10	REAR AXLES MAINTENANCE	
Section I	Introduction	10-1
Section II	Maintenance Procedures	10-1
CHAPTER 11	BRAKE SYSTEM MAINTENANCE	
Section I	Introduction	11-1
Section II	Maintenance Procedures	11-1
CHAPTER 12	WHEEL AND TIRE MAINTENANCE	
Section I	Introduction	12-1
Section II	Maintenance Procedures	12-1
CHAPTER 13	STEERING SYSTEM MAINTENANCE	
Section I	Introduction	13-1
Section II	Maintenance Procedures	13-1

TABLE OF CONTENTS (CONT)

	Page
CHAPTER 14	FRAME MAINTENANCE
Section I	Introduction 14-1
Section II	Maintenance Procedures 14-1
CHAPTER 15	SUSPENSION SYSTEM MAINTENANCE
Section I	Introduction 15-1
Section II	Maintenance Procedures 15-1
CHAPTER 16	CAB AND BODY MAINTENANCE
Section I	Introduction 16-1
Section II	Maintenance Procedures 16-1
CHAPTER 17	WINCHES MAINTENANCE
Section I	Introduction 17-1
Section II	Maintenance Procedures 17-1
CHAPTER 18	SPECIAL PURPOSE KITS MAINTENANCE
Section I	Introduction 18-1
Section II	Maintenance Procedures 18-1
APPENDIX A	REFERENCES A-1
APPENDIX B	EXPENDABLE/DURABLE SUPPLIES AND MATERIALS LIST
Section I	Introduction B-1
Section II	Expendable/Durable Supplies and Materials List B-1
APPENDIX C	ILLUSTRATED LIST OF MANUFACTURED ITEMS
Section I	Introduction C-1
Section II	Illustrated List of Manufactured Items C-1
APPENDIX D	TORQUE VALUES D-1
APPENDIX E	COMMON TOOLS, SUPPLEMENTS, AND SPECIAL TOOLS/FIXTURES LIST
Section I	Introduction E-1
Section II	Common Tools, Supplements, and Special Tools/Fixtures List E-1
APPENDIX F	MANDATORY REPLACEMENT ITEMS
Section I	Introduction F-1
Section II	Mandatory Replacement Items List F-1
SUBJECT INDEX Index-1

TABLE OF CONTENTS (CONT)
GENERAL SUPPORT MAINTENANCE

		Page
CHAPTER 19	ENGINE MAINTENANCE	
Section I	Introduction	19-1
Section II	Service Upon Receipt	19-1
Section III	Maintenance Procedures	19-2
CHAPTER 20	FUEL SYSTEM MAINTENANCE	
Section I	Introduction	20-1
Section II	Maintenance Procedures	20-1
CHAPTER 21	COOLING SYSTEM MAINTENANCE	
Section I	Introduction	21-1
Section II	Maintenance Procedures	21-1
CHAPTER 22	TRANSMISSION MAINTENANCE	
Section I	Introduction	22-1
Section II	Service and Inspection	22-1
Section III	Maintenance Procedures	22-3
CHAPTER 23	TRANSFER CASE MAINTENANCE	
Section I	Introduction	23-1
Section II	Maintenance Procedures	23-1
CHAPTER 24	FRONT AXLE MAINTENANCE	
Section I	Introduction	24-1
Section II	Maintenance Procedures	24-1
CHAPTER 25	REAR AXLES MAINTENANCE	
Section I	Introduction	25-1
Section II	Maintenance Procedures	25-1
CHAPTER 26	BRAKE SYSTEM MAINTENANCE	
Section I	Introduction	26-1
Section II	Maintenance Procedures	26-1
CHAPTER 27	STEERING SYSTEM MAINTENANCE	
Section I	Introduction	27-1
Section II	Maintenance Procedures	27-1
CHAPTER 28	WINCHES MAINTENANCE	
Section I	Introduction	28-1
Section II	Maintenance Procedures	28-1

TABLE OF CONTENTS (CONT)

		Page
APPENDIX A	REFERENCES	A-1
APPENDIX B	EXPENDABLE/DURABLE SUPPLIES AND MATERIALS LIST	
Section I	Introduction	B-1
Section II	Expendable/Durable Supplies and Materials List	B-1
APPENDIX C	ILLUSTRATED LIST OF MANUFACTURED ITEMS	
Section I	Introduction	C-1
Section II	Illustrated List of Manufactured Items	C-1
APPENDIX D	TORQUE VALUES	D-1
APPENDIX E	COMMON TOOLS, SUPPLEMENTS, AND SPECIAL TOOLS/FIXTURES LIST	
Section I	Introduction	E-1
Section II	Common Tools, Supplements, and Special Tools/Fixtures List	E-1
APPENDIX F	MANDATORY REPLACEMENT ITEMS	
Section I	Introduction	F-1
Section II	Mandatory Replacement Items List	F-1
SUBJECT INDEX		Index-1

HOW TO USE THIS MANUAL

OVERVIEW

This technical manual (TM) is provided to help you maintain the HET Tractor at the direct support and general support maintenance levels. Because of its size, it is divided into two volumes. Volume 1 contains the following major sections in order of appearance:

- **WARNING SUMMARY.** Provides a summary of the most important warnings that apply throughout the manual.
- **TABLE OF CONTENTS.** Lists, for both volumes, the chapters, sections, appendixes, and index with page numbers in order of appearance.
- **CHAPTER 1, INTRODUCTION.** Describes the HET Tractor and provides equipment data.
- **CHAPTER 2, VEHICLE MAINTENANCE.** This chapter contains information for finding tools; special tools; test, measurement, and diagnostic equipment (TMDE); and repair parts. It also contains the troubleshooting tables.

The maintenance chapters in volume 1 each contain direct support maintenance instructions for a specific system or group of components.

- **CHAPTER 3, ENGINE MAINTENANCE**
- **CHAPTER 4, FUEL SYSTEM MAINTENANCE**
- **CHAPTER 5, COOLING SYSTEM MAINTENANCE**
- **CHAPTER 6, ELECTRICAL SYSTEM MAINTENANCE**
- **CHAPTER 7, TRANSMISSION MAINTENANCE**
- **CHAPTER 8, TRANSFER CASE MAINTENANCE**
- **CHAPTER 9, FRONT AXLE MAINTENANCE**
- **CHAPTER 10, REAR AXLE MAINTENANCE**
- **CHAPTER 11, BRAKE SYSTEM MAINTENANCE**
- **CHAPTER 12, WHEEL AND TIRE MAINTENANCE**
- **CHAPTER 13, STEERING SYSTEM MAINTENANCE**
- **CHAPTER 14, FRAME MAINTENANCE**
- **CHAPTER 15, SUSPENSION SYSTEM MAINTENANCE**
- **CHAPTER 16, CAB AND BODY MAINTENANCE**
- **CHAPTER 17, WINCHES MAINTENANCE**
- **CHAPTER 18, SPECIAL PURPOSE KITS MAINTENANCE**

The last part of volume 1 contains information which will assist you in the performance of direct support and general support maintenance of the HET Tractor.

- **APPENDIX A, REFERENCES.** Lists publications used with the HET Tractor.
- **APPENDIX B, EXPENDABLE/DURABLE SUPPLIES AND MATERIALS LIST.** Lists expendable and durable items used in the performance of maintenance.

OVERVIEW (CONT)

- **APPENDIX C, ILLUSTRATED LIST OF MANUFACTURED ITEMS.** Illustrates and describes items that must be fabricated from bulk materials for repair of the HET Tractor.
- **APPENDIX D, TORQUE VALUES.** Lists the standard torques values for specific attaching hardware.
- **APPENDIX E, COMMON TOOLS, SUPPLEMENTS, AND SPECIAL TOOLS/FIXTURES LIST.** This appendix lists equipment used in the performance of maintenance and references publications which contain information regarding the equipment.
- **APPENDIX F, MANDATORY REPLACEMENT ITEMS LIST.** This appendix lists parts required for use in the performance of maintenance procedures, their part numbers, and NSNs.
- **SUBJECT INDEX.** Lists important subjects contained in volume 1 in alphabetical order and gives the paragraph numbers on which they are located.

Volume 2 contains the following major sections in order of appearance:

- **WARNING SUMMARY.** Provides a summary of the most important warnings that apply throughout the manual.
- **TABLE OF CONTENTS.** Lists, for volume 2, the chapters, sections, appendixes, and index with page numbers in order of appearance.

The maintenance chapters in volume 2 each contain general support maintenance instructions for a specific system or group of components.

- **CHAPTER 19, ENGINE MAINTENANCE**
- **CHAPTER 20, FUEL SYSTEM MAINTENANCE**
- **CHAPTER 21, COOLING SYSTEM MAINTENANCE**
- **CHAPTER 22, TRANSMISSION MAINTENANCE**
- **CHAPTER 23, TRANSFER CASE MAINTENANCE**
- **CHAPTER 24, FRONT AXLE MAINTENANCE**
- **CHAPTER 25, REAR AXLES MAINTENANCE**
- **CHAPTER 26, BRAKE SYSTEM MAINTENANCE**
- **CHAPTER 27, STEERING SYSTEM MAINTENANCE**
- **CHAPTER 28, WINCHES MAINTENANCE**

The last part of volume 2 contains information which will assist you in the performance of direct support and general support maintenance of the HET Tractor.

- **APPENDIX A, REFERENCES.** Lists publications used with the HET Tractor.
- **APPENDIX B, EXPENDABLE/DURABLE SUPPLIES AND MATERIALS LIST.** Lists expendable and durable items used in the performance of maintenance.
- **APPENDIX C, ILLUSTRATED LIST OF MANUFACTURED ITEMS.** Illustrates and describes items that must be fabricated from bulk materials for repair of the HET Tractor.

OVERVIEW (CONT)

- **APPENDIX D, TORQUE VALUES.** Lists the standard torques values for specific attaching hardware.
- **APPENDIX E, COMMON TOOLS, SUPPLEMENTS, AND SPECIAL TOOLS/FIXTURES LIST.** This appendix lists equipment used in the performance of maintenance and references publications which contain information regarding the equipment.
- **APPENDIX F, MANDATORY REPLACEMENT ITEMS LIST.** This appendix lists parts required for use in the performance of maintenance procedures, their part numbers, and NSNs.
- **SUBJECT INDEX.** Lists important subjects contained in volume 2 in alphabetical order and gives the paragraph numbers in which they are located.

FINDING INFORMATION

There are several ways to find the information you need in this manual. They are as follows:

- **FRONT COVER INDEX.** The front cover index contains a list of the most important topics contained in each volume. It features a black box at the right edge of the cover which corresponds with a black box on the page containing the topic. The topics listed on the front cover are highlighted in the table of contents with a box.
- **TABLE OF CONTENTS.** Lists chapters, sections, appendixes, and index with page numbers in order of appearance.
- **CHAPTER INDEXES.** List paragraphs contained in the individual chapters with paragraph and page numbers in order of appearance.
- **SYMPTOM INDEX.** Lists malfunctions contained in the troubleshooting table with page numbers in order of appearance.
- **SUBJECT INDEX.** Lists all important topics with paragraph numbers in alphabetical order.

TROUBLESHOOTING

When a malfunction occurs, look at the symptom index for the vehicle troubleshooting table in chapter 2. Find the malfunction in the index. Turn to the page number listed for the malfunction in the troubleshooting table. Perform the steps required to correct the malfunction. If you can't find the malfunction, or the malfunction is not corrected, notify your supervisor. Refer to para 2-4, Introduction to Logic Tree Troubleshooting, for additional troubleshooting instructions.

MAINTENANCE

Maintenance instructions are located in chapters 3 thru 28. The troubleshooting tables often reference you to these procedures. When you perform maintenance, look over the entire procedure before starting. Make sure you have the necessary tools and materials at hand. Always follow the WARNINGS and CAUTIONS.

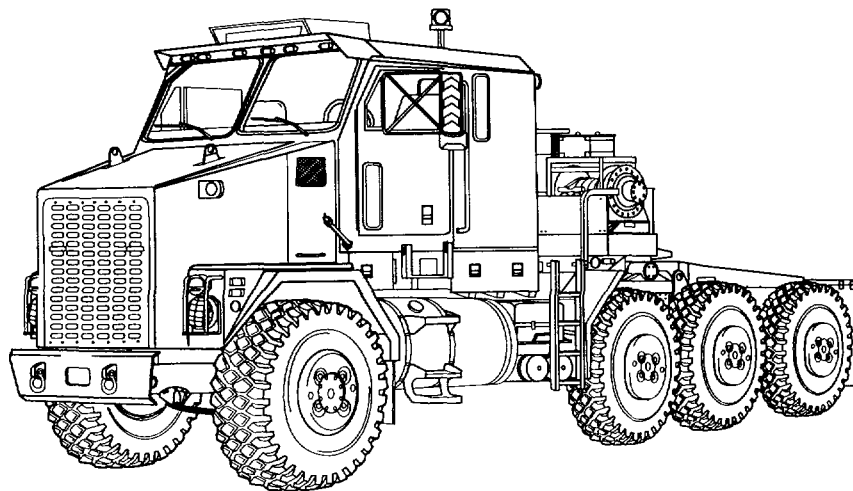

Left Front View

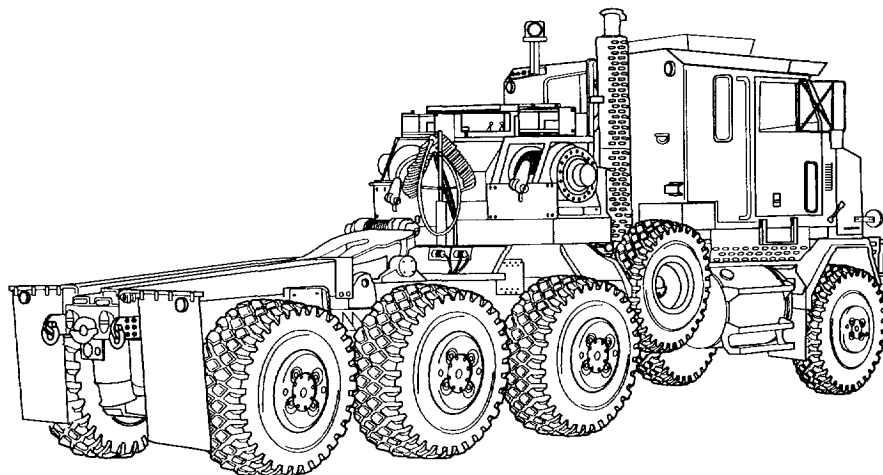

Right Rear View

**TRUCK, TRACTOR, M1070, 8 X 8,
HEAVY EQUIPMENT TRANSPORTER (HET)**

CHAPTER 1
INTRODUCTION

Contents	Para	Page
Scope	1-1	1-1
Maintenance Forms, Records, and Reports	1-2	1-1
Destruction of Army Materiel to Prevent Enemy Use	1-3	1-1
Preparation for Storage or Shipment	1-4	1-2
Nomenclature Cross-Reference	1-5	1-2
Reporting Equipment Improvement Recommendations (EIR)	1-6	1-2
Equipment Improvement Report and Maintenance Digest (EIR MD) and Equipment Improvement Report and Maintenance Summary (EIR MS)	1-7	1-2
Warranty Information	1-8	1-2
Metric System	1-9	1-3
Equipment Characteristics, Capabilities, and Features	1-10	1-3
Location and Description of Components	1-11	1-3
Equipment Data	1-12	1-3
Safety, Care, and Handling	1-13	1-3
Power Train	1-14	1-4
Electrical System	1-15	1-5
Steering System	1-16	1-7
Air System	1-17	1-8
Winch System	1-18	1-10

Section I. GENERAL INFORMATION

1-1. SCOPE

- a. Type of Manual.** Direct Support and General Support Maintenance Instructions, TM 9-2320-360-34.
- b. Model Number and Equipment Name.** Truck, Tractor, M1070, 8 X 8, Heavy Equipment Transporter (HET).
- c. Purpose of Equipment.** The HET Tractor and the M1000 Trailer form the Heavy Equipment Transport System (HETS). HETS will be used to load, unload, and transport the M1 Series Main Battle Tank (MBT) during administrative and tactical operations.

1-2. MAINTENANCE FORMS, RECORDS, AND REPORTS

Department of the Army forms and procedures used for equipment maintenance will be those prescribed by DA Pam 738-750, The Army Maintenance Management System (TAMMS).

1-3. DESTRUCTION OF ARMY MATERIEL TO PREVENT ENEMY USE

Command decision, according to tactical situation, will determine when the destruction of the HET Tractor will be accomplished. A destruction plan will be prepared by the using organization unless one has been prepared by a higher authority. For general destruction procedures for this equipment, refer to TM 750-244-6, Procedures for Destruction of Tank-Automotive Equipment to Prevent Enemy Use (U.S. Army Tank-Automotive Command).

1-4. PREPARATION FOR STORAGE OR SHIPMENT

Instructions for preparation for storage or shipment are provided in paragraph 2-14 of this manual.

1-5. NOMENCLATURE CROSS-REFERENCE

Table 1-1 lists the nomenclature cross-references used in this manual.

Table 1-1. Nomenclature Cross-Reference

Common Name	Official Nomenclature
DDR	CTS J1708 Application
STE/ICE-R	CTS/ICE
Cable	Wire rope
Cold Start System	Ether quick-start system
Engine Coolant	Antifreeze, ethylene glycol mixture
Gladhand	Quick-disconnect coupling
HET Tractor	Truck, Tractor, M1070, 8 x 8, Heavy Equipment Transporter (HET)
Jacobs Brake	Engine retarder

1-6. REPORTING EQUIPMENT IMPROVEMENT RECOMMENDATIONS (EIR)

If your HET Tractor needs improvement, let us know. Send us an EIR. You, the user, are the only one who can tell us what you don't like about your equipment. Let us know why you don't like the design. Put it on an SF 368 (Quality Deficiency Report). Mail it to us at: Commander, U.S. Army Tank-Automotive and Armaments Command, ATTN: AMSTA-QRT, Warren, MI 48397-5000. We'll send you a reply.

1-7. EQUIPMENT IMPROVEMENT REPORT AND MAINTENANCE DIGEST (EIR MD) AND EQUIPMENT IMPROVEMENT REPORT AND MAINTENANCE SUMMARY (EIR MS)

The quarterly EIR MD, TB 43-001-39 series, contains valuable field information on the equipment covered in this manual. It is compiled from some of the Quality Deficiency Reports that have been prepared on the vehicles covered in this manual. Many of these articles result from comments, suggestions, and improvement recommendations that were submitted to the EIR program. It also contains information on equipment improvements, minor alterations, proposed Modification Work Orders (MWOs), warranties, actions taken on some of the DA Form 2028's (Recommended Changes to Publications), and advance information on proposed changes that may affect this manual. In addition, the more maintenance significant articles (including minor alterations, field-fixes, etc.) that have a continuing need in the field are republished in the EIR MS for TACOM equipment (TM 43-1043). Refer to both of these publications periodically, especially the TB 43-001-39 series, for the most current and authoritative information on the equipment. The information will help you to do a better job and will advise of the latest changes to this manual. Also refer to DA Pam 25-30, Consolidated Index of Army Publications and Blank Forms, and appendix A, References, of this manual.

1-8. WARRANTY INFORMATION

The HET Tractor is warranted by Oshkosh Truck Corporation for 18 months. Warranty starts on the date found in block 23, DA Form 2408-9, in the logbook. Report all defects in material or workmanship to the supervisor, who will take the appropriate action. For complete information covering warranties, refer to Warranty Technical Bulletin for Truck, Tractor, M1 070, 8 x 8, Heavy Equipment Transporter (HET), TB 9-2320-360-14.

1-9. METRIC SYSTEM

The equipment described herein contains metric components and requires metric common and special tools, therefore, metric units in addition to English units will be used throughout this manual. An English-to-metric conversion table is included inside the back cover of this manual.

Section II. EQUIPMENT DESCRIPTION AND DATA

1-10. EQUIPMENT CHARACTERISTICS, CAPABILITIES, AND FEATURES

Refer to TM 9-2320-360-10 for equipment characteristics, capabilities, and features.

1-11. LOCATION AND DESCRIPTION OF COMPONENTS

Refer to TM 9-2320-360-10 for location and description of components.

1-12. EQUIPMENT DATA

Refer to TM 9-2320-360-10 for equipment data.

1-13. SAFETY, CARE, AND HANDLING

a. Significant Hazards and Safety Recommendations. Significant hazards and safety recommendations are listed in table 1-2.

Table 1-2. Significant Hazards and Safety Recommendations

Operating Hazard	Safety Recommendation or Precaution	Condition*
Low oil pressure/ high coolant temperature	Stop engine operation when CHECK GAUGES and CHECK ENGINE indicators are lit, engine warning alarm sounds, and gages indicate abnormal readings.	Abnormal
Low air pressure	Do not drive HET Tractor while low air pressure alarm is sounding or LOW AIR indicator is lit.	Abnormal
Electric shock	Do not wear watches, rings, or other jewelry while working on or near an electrical circuit.	Abnormal
Refueling vehicle	Fuel is very flammable and can explode easily. To avoid serious injury or death, keep fuel away from open flame and keep fire extinguisher within easy reach when working with fuel. Do not work on fuel system when engine is hot. Fuel can be ignited by hot engine. When working with fuel, post sign that says: NO SMOKING WITHIN 50 FEET OF VEHICLE.	Normal

*Category of hazards as to whether or not they may be expected under normal or abnormal operating conditions.

1-13. SAFETY, CARE, AND HANDLING (CONT)

Table 1-2. Significant Hazards and Safety Recommendations (Cont)

Operating Hazard	Safety Recommendation or Precaution	Condition*
Connecting/Disconnecting trailer.	Make sure that position of assistant is known at all times. Make sure no one is standing directly behind tractor or trailer during connection/ disconnection.	Normal
Vehicle instability on a hill.	Avoid driving diagonally across a hill. HET Tractor may roll, causing equipment damage and injury or death to personnel.	Normal
Winching operations.	Do not use winches for lifting personnel. Always wear heavy gloves when handling winch cable. Never let cable run through hands. Frayed cable can cut severely. Do not operate winch without guard in place. Do not place hands or feet near winch during operation. Ensure that both DRIVER SIDE and PASSENGER SIDE WINCH KICKOUT controls are disengaged prior to paying out winch cables. Failure to disengage KICKOUT controls may result in injury to personnel.	Normal
*Category of hazards as to whether or not they may be expected under normal or abnormal operating conditions.		

Section III. PRINCIPLES OF OPERATION

1-14. POWER TRAIN

Power for the HET Tractor is generated by a two-stroke, V-type diesel engine coupled directly to an automatic transmission. The engine is capable of 500 horsepower of braking.

The engine is equipped with an electronic control system that regulates fuel delivery to each injector as well as governing engine speed for power takeoff operation. Engine sensors and engine performance can be checked using a plug-in diagnostic reader.

Five forward drive ranges can be manually selected, depending on the terrain and conditions. The transmission will automatically downshift as engine speed and throttle position change.

When the lockup clutch is automatically applied, power is transmitted mechanically through the lockup clutch. A direct drive is engaged from the engine to a converter turbine shaft.

Power from the transmission is directed to the transfer case and propeller shafts forward and rear. The front axle and rear tridem axles are each equipped with planetary wheel ends. In low range, driver-controlled lockouts in the differentials provide positive drive to all four axles.

1-15. ELECTRICAL SYSTEM

The HET Tractor electrical system consists of two different circuits, 12 Vdc and 24 Vdc. Four 12-volt storage batteries (1) connected in series parallel provide current to both circuits. Two belt-driven alternators provide current to the electrical system during normal operation, and recharge the batteries while the engine is operating. The 24 Vdc system utilizes an alternator (2) with 130 amp capacity. The 12 Vdc system utilizes an alternator (3) with 145 amp capacity.

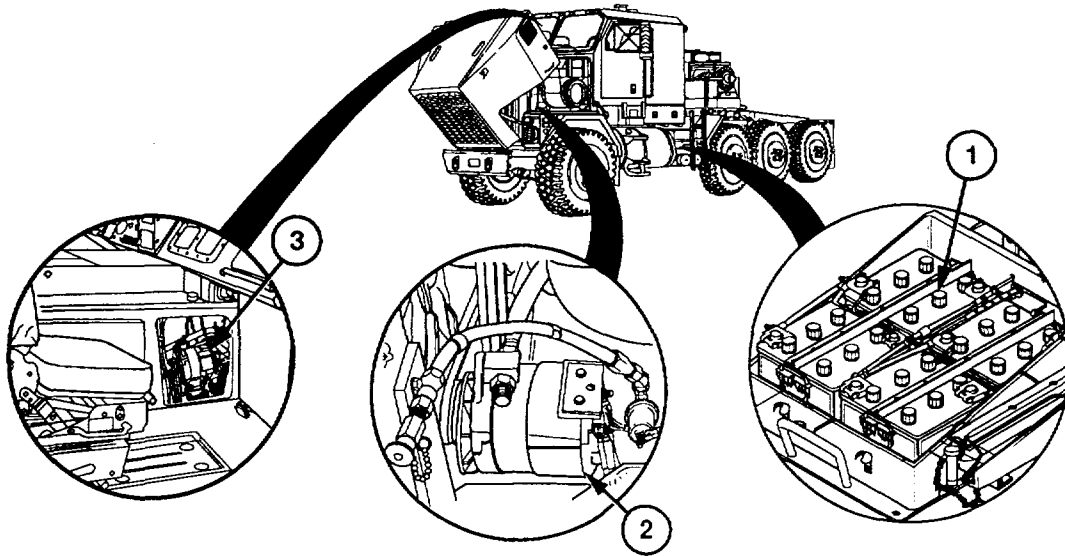

The headlights (4), windshield wipers (5), washer, instrument panel/dash lighting switches (6), warning lights, and gages are supplied with 12 Vdc.

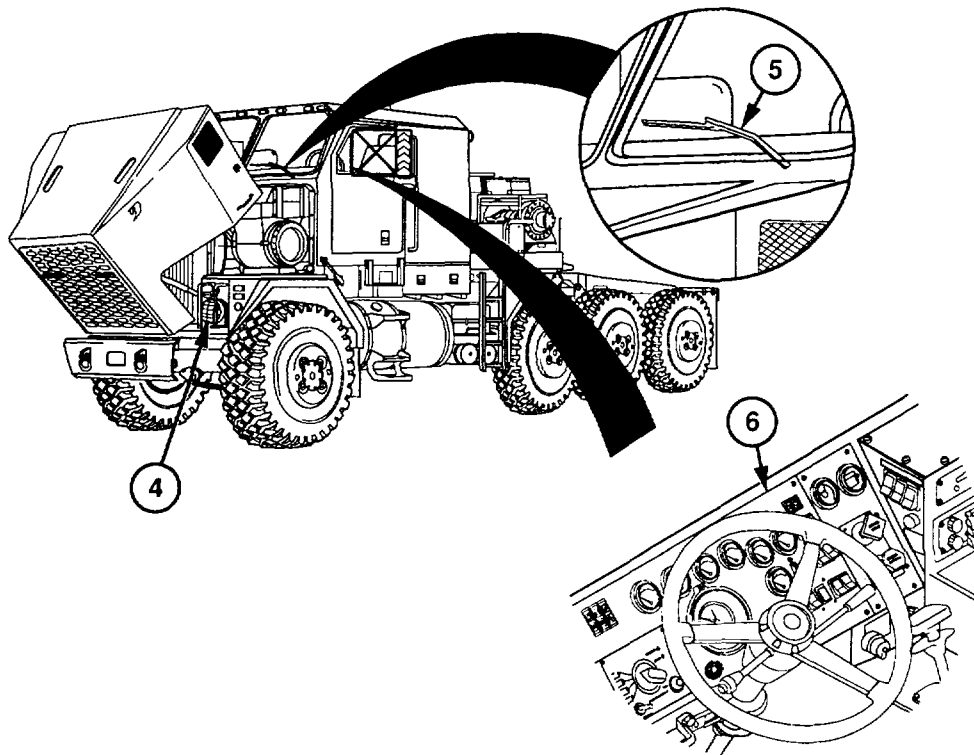

1-15. ELECTRICAL SYSTEM (CONT)

The starter motor (7), winches (8), CTIS, air dryers (9), trailer lights, and ether injection system (10) are operated with 24 Vdc.

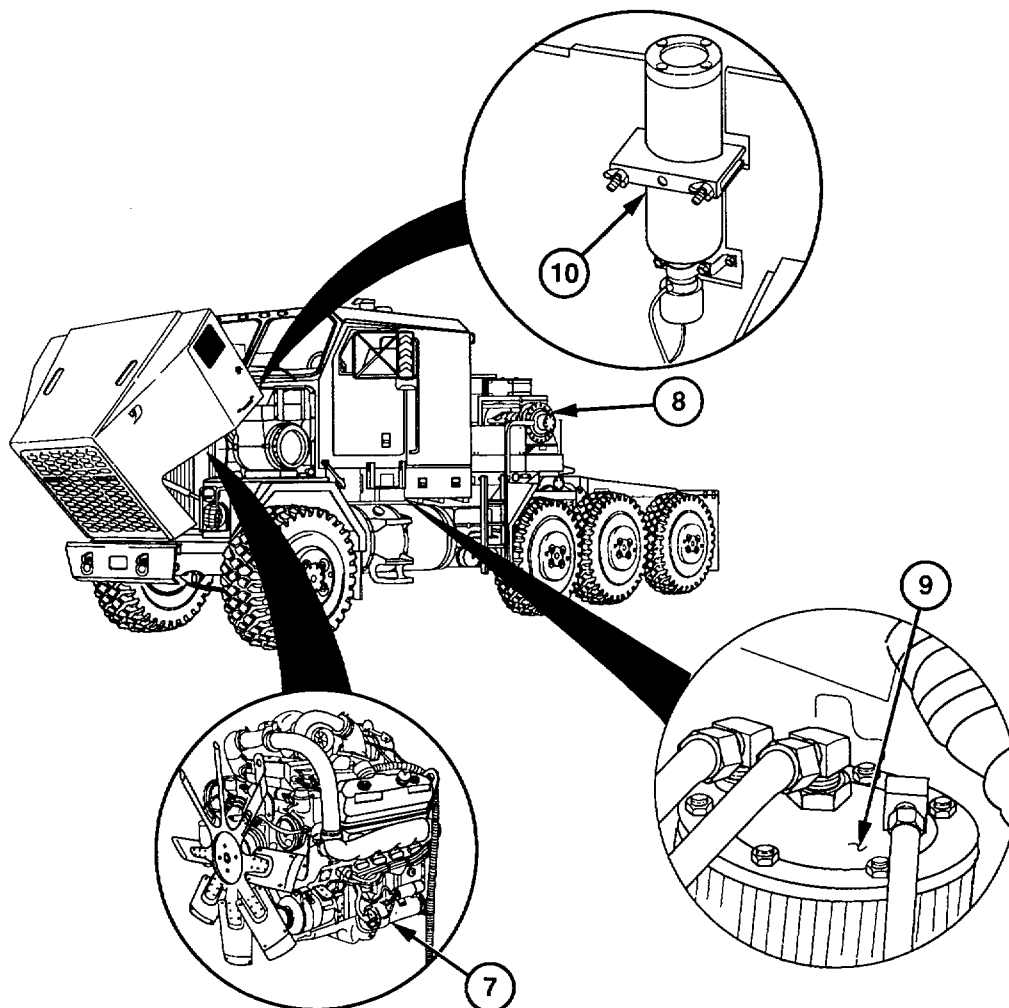

The starter motor solenoid receives 24 Vdc from the storage batteries through the engine starter magnetic switch auxiliary contacts and the neutral start relay. If the transmission range selector is not in the N (neutral) position prior to startup, the engine cannot be started.

Warning lights and gages that indicate system malfunctions include: CHECK GAUGES alarm, CHECK ENGINE indicator, and CHECK GAUGES indicator.

1-16. STEERING SYSTEM

The steering system uses two steering axles, one at the front (1) and one at the rear (2). Each axle turns in response to turning the steering wheel (3) in the cab.

Steering power is generated by a steering pump (4) driven directly at the engine providing pressure to two steering gears (5), one at each steering axle. The pump delivers hydraulic fluid to enable the operator to turn the wheels of a fully-loaded truck. An interconnected series of shaft linkages rotate with hydraulic power assist to turn the two axles.

As the steering wheel is turned, the rotational motion of the upper steering assembly shafts (6) is translated at a tee gear box (7) below the cab to both the front and rear power steering gears (5). The gear boxes multiply the rotational force to a pair of drag links (8) and axle steering arms that apply directional motion to turn the axles.

In the event a steering line (9) to a steering axle is severed or fluid leaks from the system (power steering inoperable), the truck can be steered for short distances in emergency situations.

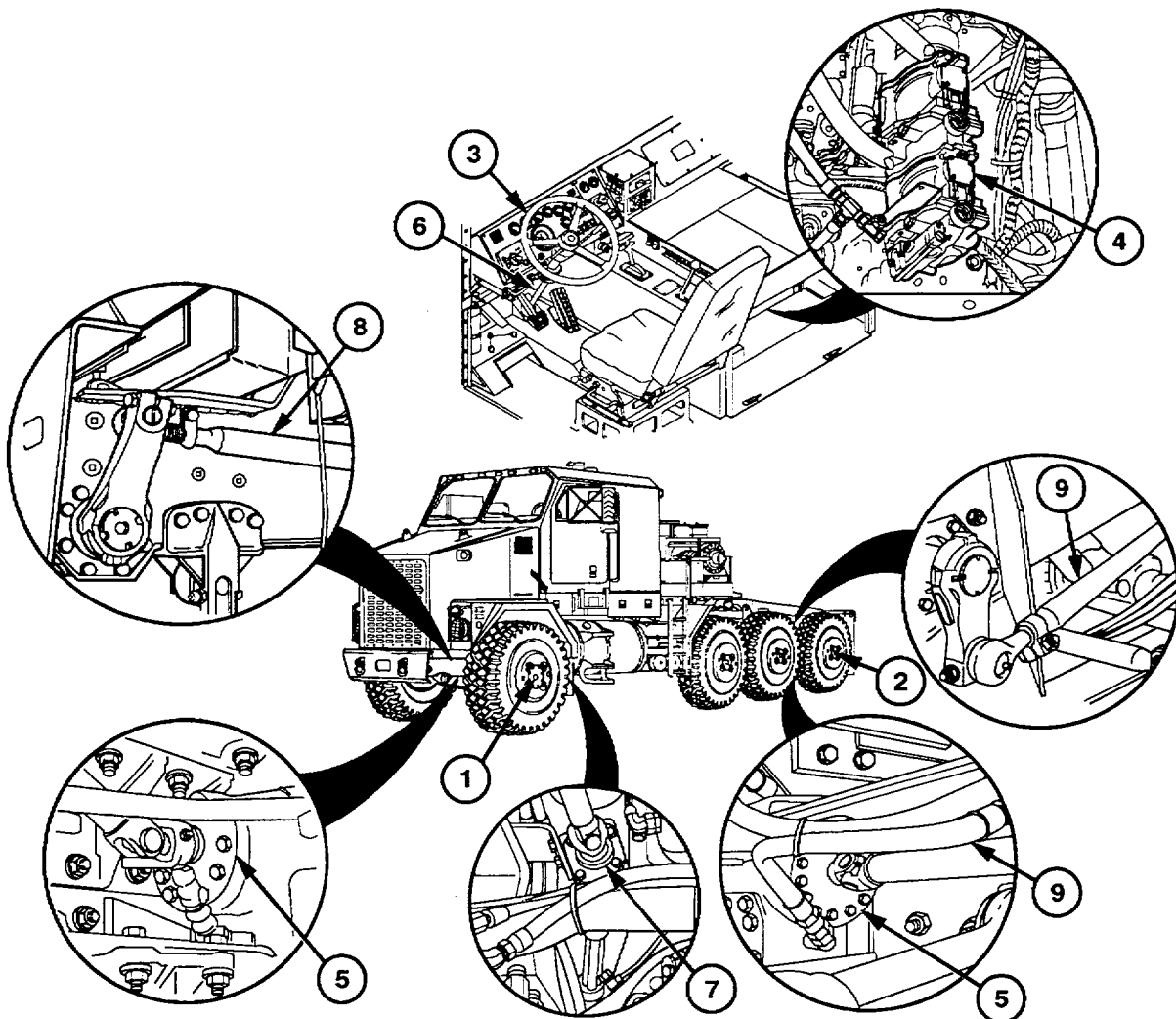

1-17. AIR SYSTEM

The air system operates the service and parking brakes, rear suspension system, and the Central Tire Inflation System (CTIS). Air also enables operation of the transfer case and interaxle lockups, winch tensioners and kickouts, windshield washer, and horns.

The air system on the HET Tractor consists of an engine-driven air compressor (1), a purge tank (2), and five air reservoirs (3 thru 7). Reservoir (3) supplies air to reservoirs (4 thru 7). Three reservoirs (5 thru 7) are interconnected and separated from reservoir (4) with check valves. Air from reservoir (4) is supplied to service brakes on all four axles and parking brakes on the rear tridem axles, transfer case and interaxle lockups, winch tensioners and kickouts, windshield washer, and horns. The service brakes are actuated by relay valves which are controlled by the operator pressing the brake treadle in the cab. The parking brakes are also actuated by relay valves which are controlled by hand controls. In the event of the loss of system air pressure, the spring brake valve will modulate the parking brakes so the HET Tractor can be stopped safely. Reservoirs (5 thru 7) supply air to operate the CTIS, service and parking brakes on rear tridem axles, and rear suspension system. Air is drawn from the engine air intake and routed to the air compressor (1) where it is pressurized. Pressurized air flows from the air compressor (1) through an aftercooler (7.1), a coalescing filter (7.2), and air dryers (8 and 9) where the air is cooled and moisture/oil is removed. Air from the dryers goes to the purge reservoir (2) and air reservoir (3).

System protection elements include an air cleaner restriction sensor that determines whether air flow through the air cleaner is impeded and also transmits a signal to a dash-mounted gage.

In the cab, air pressure in reservoir (4) is indicated by the green needle on the AIR PRESS gage (10). The red needle on the gage (10) indicates air pressure in reservoirs (5 thru 7). If air pressure falls below 60 psi (414 kPa) in any of the reservoirs, warning alarm will sound and LOW AIR indicator will light.

The rear suspension system contains a pair of suspension air bags on each rear axle that automatically inflates or deflates according to load. Air to the air bags is regulated by a height control valve.

Purging the air in the air dryers and aftercooler is automatically done when 125 psi (862 kPa) system pressure is reached at the compressor. The compressor cycle is stopped and air from purge tank clears accumulated water through a valve on the bottom of the air dryer.

Air to the transfer case enables engagement of four-wheel drive in high or low gear range. An interaxle lockup pilot valve also prevents the axles from locking up in high range.

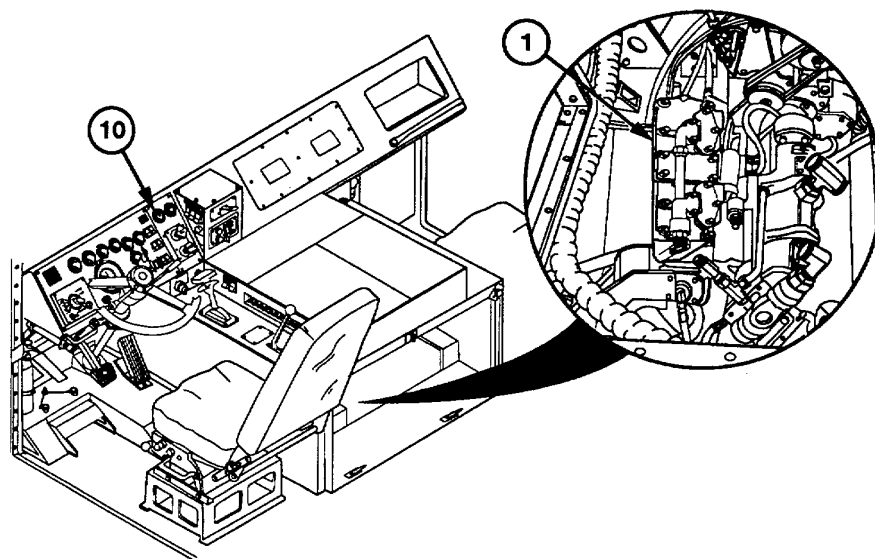

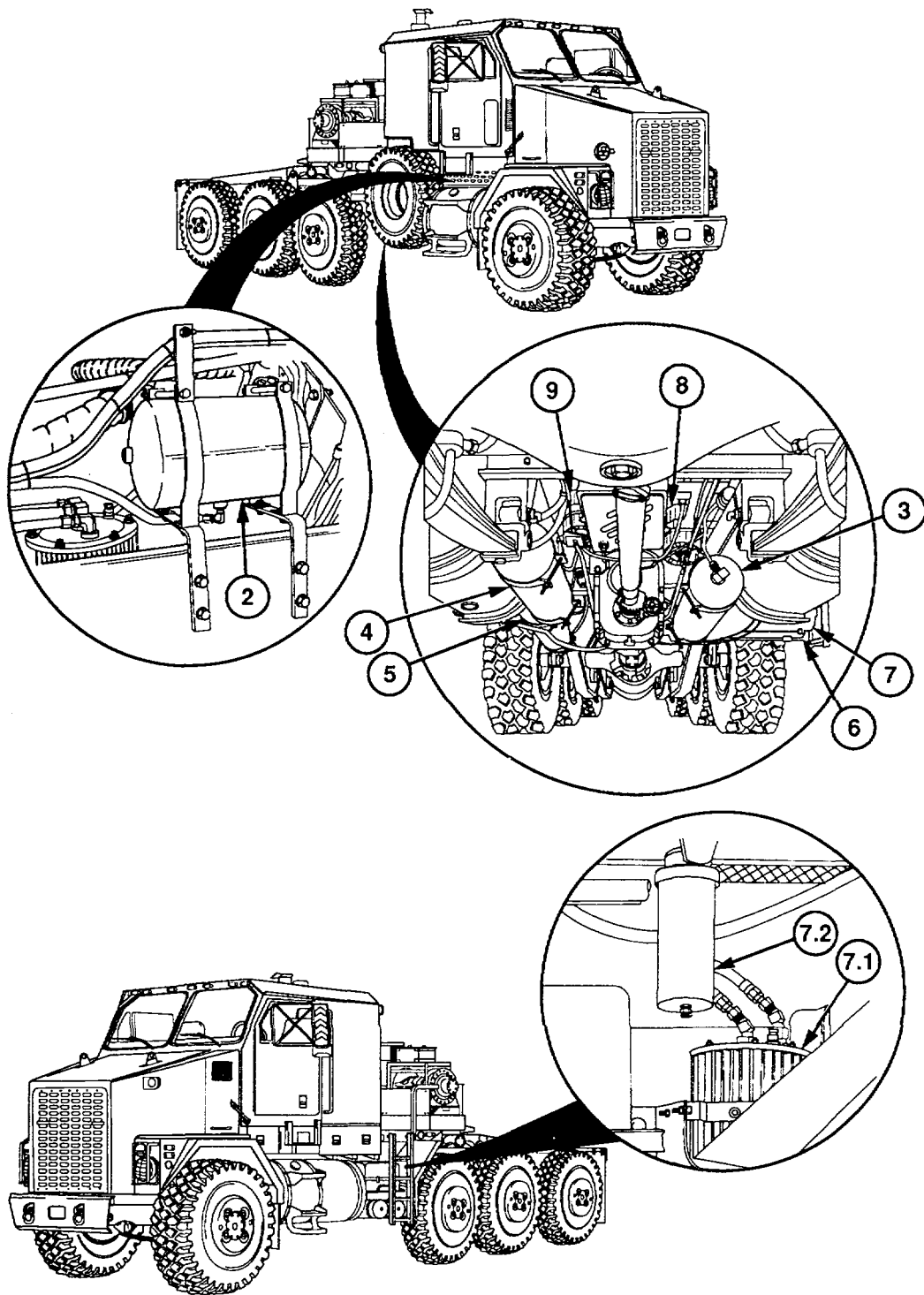

1-18. WINCH SYSTEM

The winch system operates hydraulically and consists of two main winches (1 and 2) and an auxiliary winch (3). The main winches operate independently of each other and are used to recover, load, and unload heavy tracked and wheeled vehicles. The main winches are mounted side-by-side directly to the winch platform. The auxiliary winch is used to pull the main winch cable out to the payload. The auxiliary winch is mounted to the winch platform just below the driver's side main winch.

The winches are controlled from the operator's station (4). The operator is protected by a personnel guard during winch operations. The main winch controls are the winch kickout control, cable hold down lever, engine idle selector switch, engine high idle lock switch, winch speed control switch, and the winch drum control.

Each main winch incorporates a two-speed hydraulic motor (5 and 6). The hydraulic motor is used to provide power. It converts hydraulic horsepower from the pump and control circuitry to rotary mechanical horsepower for driving the gear system. A single-speed motor (7) is used by the auxiliary winch. A Power Takeoff (PTO) driven hydraulic pump (8) supplies the winch system with hydraulic oil from the reservoir (9). A two-piece driveshaft connects the transmission driven PTO to the hydraulic pump (8). A view gage (10) on the reservoir indicates the hydraulic oil level. All winches have a fail-safe brake and winch brake valve for winch load control.

