

TECHNICAL MANUAL

ORGANIZATIONAL MAINTENANCE

VOLUME 1 OF 3

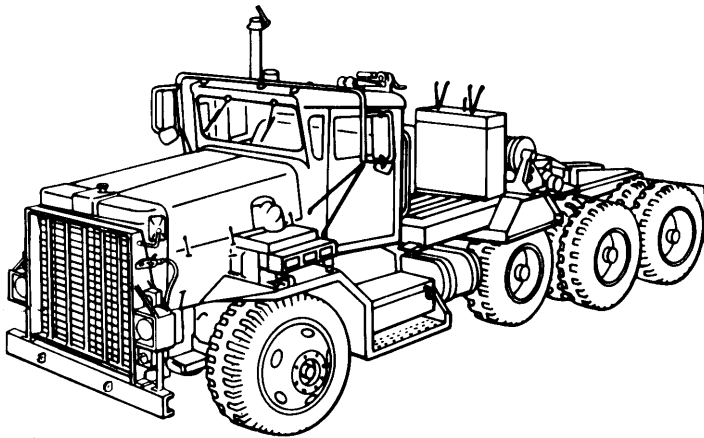

HOW TO USE THIS MANUAL PAGE iii
INTRODUCTION PAGE 1-1
PREVENTIVE MAINTENANCE CHECKS AND SERVICES (PMCS) PAGE 2-4
TROUBLESHOOTING PAGE 3-1
MAINTENANCE INSTRUCTIONS PAGE 4-1
INDEX PAGE Index-1

**TRUCK, TRACTOR, COMMERCIAL
HEAVY EQUIPMENT TRANSPORTER
(C-H ET) 85,000 GVWR, 8 x 6, M911
(NSN 2320-01-025-3733)**

JUNE 86

HEADQUARTERS, DEPARTMENT OF THE ARMY

TECHNICAL MANUAL }
 NO. 9-2320-270-20-1 }

HEADQUARTERS
 DEPARTMENT OF THE ARMY
 Washington, D. C., 14 June 1986

ORGANIZATIONAL MAINTENANCE MANUAL

**TRUCK, TRACTOR, COMMERCIAL
 HEAVY EQUIPMENT TRANSPORTER (C-HET)
 85,000 GVWR, 8 X 6, M911
 (NSN 2320-01-025-3733)**

CURRENT AS OF NOVEMBER 1985

REPORTING ERRORS AND RECOMMENDING IMPROVEMENTS

You can help improve this manual. If you find any mistakes or if you know of a way to improve the procedures, please let us know. Mail your letter, DA Form 2028 (Recommended Changes to Publications and Blank Forms), or DA Form 2028-2 located in the back of this manual direct to: Commander, US Army Tank-Automotive Command, AITN: AMSTA-MB, Warren, MI 48397-5000. A reply will be sent to you.

TABLE OF CONTENTS

VOLUME 1 OF 3

		Page
	<u>HOW TO USE THIS MANUAL</u>	iii
CHAPTER 1	<u>INTRODUCTION</u>	1-1
Section I.	General Information	1-1
Section II.	Equipment Description and Data	1-2
Section III.	Technical Principles of Operation	1-14
CHAPTER 2	INTEGRATED SYSTEMS MAINTENANCE INSTRUCTIONS	2-1
Section I.	Repair Parts, Special Tools; Test, Measurement, and Diagnostic Equipment (TMDE); and Support Equipment	2-1
Section II.	<u>Service Upon Receipt</u>	2-1
Section III.	<u>Preventive Maintenance Checks and Services (PMCS)</u>	2-4
CHAPTER 3	<u>TROUBLESHOOTING</u>	3-1
Section I.	Troubleshooting System Index	3-1
Section II.	Troubleshooting Procedures	3-4

I This manual supersedes TM 9-2320-270-20, dated 15 November 1977.

TABLE OF CONTENTS - CONTINUED

VOLUME 1 OF 3 – CONTINUED

	Page
CHAPTER 4	
<u>MAINTENANCE INSTRUCTIONS</u>	4-1
Section I. General Maintenance Instructions	4-1
Section II. Engine System Maintenance	4-9
Section III. Fuel System Maintenance	4-31
Section IV. Exhaust System Maintenance	4-131
Section V. Cooling System Maintenance	4-143
Section VI. Electrical System Maintenance	4-214
INDEX	Index-1

VOLUME 2 OF 3

CHAPTER 4	
MAINTENANCE INSTRUCTIONS – CONTINUED	4-525
Section VII. Transmission Maintenance	4-525
Section VIII. Propeller Shaft Maintenance	4-574
Section IX. Front Axle Maintenance	4-598
Section X. Tandem Axle Maintenance	4-601
Section XI. Brake System Maintenance	4-609
Section XII. Wheels, Hubs, and Brakedrums Maintenance	4-893
INDEX	Index-1

VOLUME 3 OF 3

CHAPTER 4	
MAINTENANCE INSTRUCTIONS – CONTINUED	4-937
Section XIII. Steering	4-937
Section XIV. Frame and Towing Attachment Maintenance	4-1042
Section XV. Springs, Shock Absorbers, and Torque Rods	4-1065
Section XVI. Cab and Body Maintenance	4-1088
Section XVII. Winches	4-1135
Section XVIII. Accessories Maintenance	4-1177
Section XIX. Gages, Non-Electric	4-1330
APPENDIX A	
REFERENCES	A-1
APPENDIX B	
MAINTENANCE ALLOCATION CHART	B-1
APPENDIX C	
EXPENDABLE SUPPLIES AND MATERIALS LIST	C-1
APPENDIX D	
MANUFACTURED ITEMS (NOT APPLICABLE)	D-1

TABLE OF CONTENTS - CONTINUED

VOLUME 3 OF 3 – CONTINUED

	Page
APPENDIX E TORQUE LIMITS	E-1
APPENDIX F SCHEMATIC DIAGRAMS	F-1
GLOSSARY	Glos-1
INDEX	Index-1

HOW TO USE THIS MANUAL

1. MANUAL OVERVIEW

This manual is divided into three volumes: TM9-2320-270-20-1, TM9-2320-270-20-2, and TM 9-2320-270-20-3. It provides Organizational Maintenance troubleshooting and maintenance information.

This manual is written with several important features to make it as useful as possible:

- a. Cover index for access to important information.
- b. General maintenance instructions which provide useful information for the novice but prevent the need for routine tasks to be repeated throughout the manual.
- c. Troubleshooting and maintenance procedures written in tasks, each conforming to some system or assembly. These tasks appear in roughly the same order that the systems or assemblies appear in the RPSTL (Repair Parts and Special Tools List).
- d. An alphabetical index at the head of each section and an overall index in the rear of each volume.
- e. RPSTL names for the parts and system used whenever practical to aid cross accessing between the RPSTL and the manual. Adjectives have been added, when necessary, to clarify one part or system from another.
- f. Maintenance procedures in a three column, step by step format minimizing the number of words used and allowing you to do each task without having to look for needed information.
- g. Tools, parts, materials, and equipment conditions listed at the head of each task allowing you to acquire all things needed for each task before beginning.
- h. Each troubleshooting procedure takes you step by step from most probable and easiest to repair faults, to least likely and most difficult to repair faults.
- i. Electrical, air, and hydraulic diagrams systems are included in Appendix F.
- j. Routine repair and maintenance services listed in tabular format under the heading of Preventive Maintenance Checks and Services (PMCS).

HOW TO USE THIS MANUAL - CONTINUED

2. USING THE MANUAL

This manual is designed for easy use. For routine periodic maintenance, go to the Preventive Maintenance Checks and Services (PMCS). When you need to repair a malfunction:

- a. Find the malfunction in the Troubleshooting Symptom Index (page 3-1).
- b. Go to the troubleshooting procedure for that malfunction and locate the defective assembly and the repair or replacement work needed.
- c. There are two ways to find the maintenance procedure you need. Either look up the name of the defective assembly in the alphabetical index at the rear of each volume, or find the system on the cover index, go to the first page of the section for that system, and use the alphabetical index at the beginning of each section.
- d. Go to the task for the assembly that needs repair or replacement.
- e. Refer to the heading "This Task Covers" for the procedures you need within that task.
- f. Look under the heading "Equipment Condition" and determine what other tasks must be performed before starting the main task.
- g. Familiarize yourself with the main task, the tasks listed under Equipment Condition, and any general maintenance instructions referenced in the task before beginning. You must familiarize yourself with the entire maintenance procedure before beginning the maintenance task.
- h. Acquire the tools and materials listed in the Initial Setup as well as parts you have determined must be replaced.
- i. Make sure assistance is available if more than one person is called out in Initial Setup.
- j. Perform maintenance work as instructed in the task.
- k. Always observe the warnings in each procedure and the general warnings in the front of the manual. They are for your protection.
- l. Observe all cautions to prevent damage to the equipment.
- m. When finished with task, operate that part of the equipment as described in TM 9-2320-270-10 to be sure you have made an effective repair.

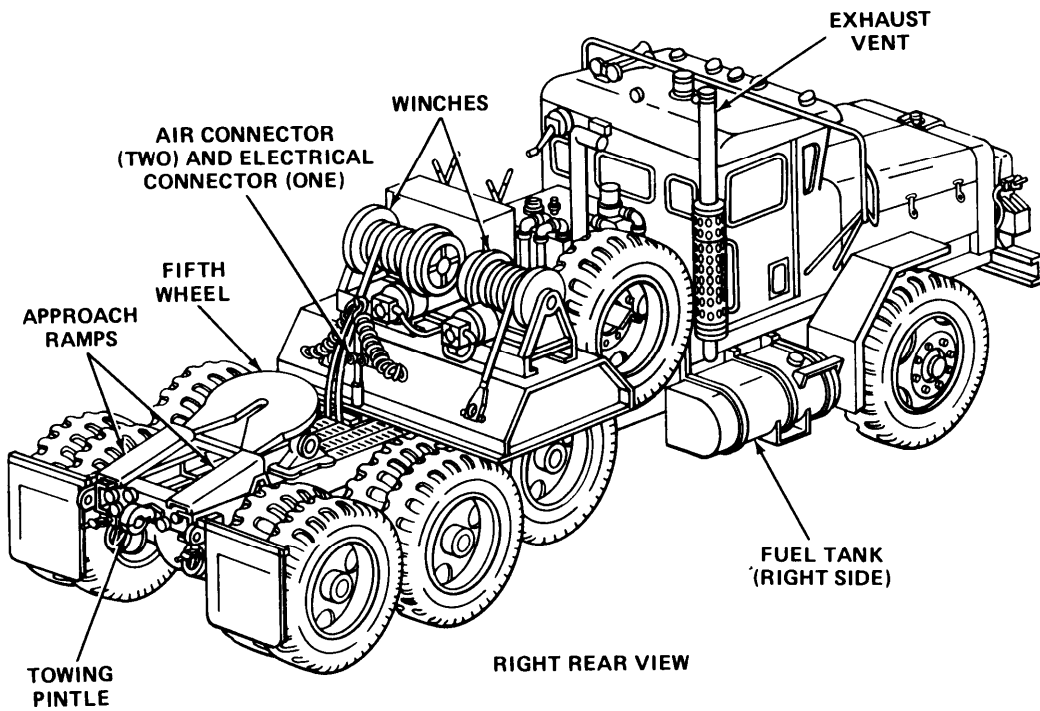
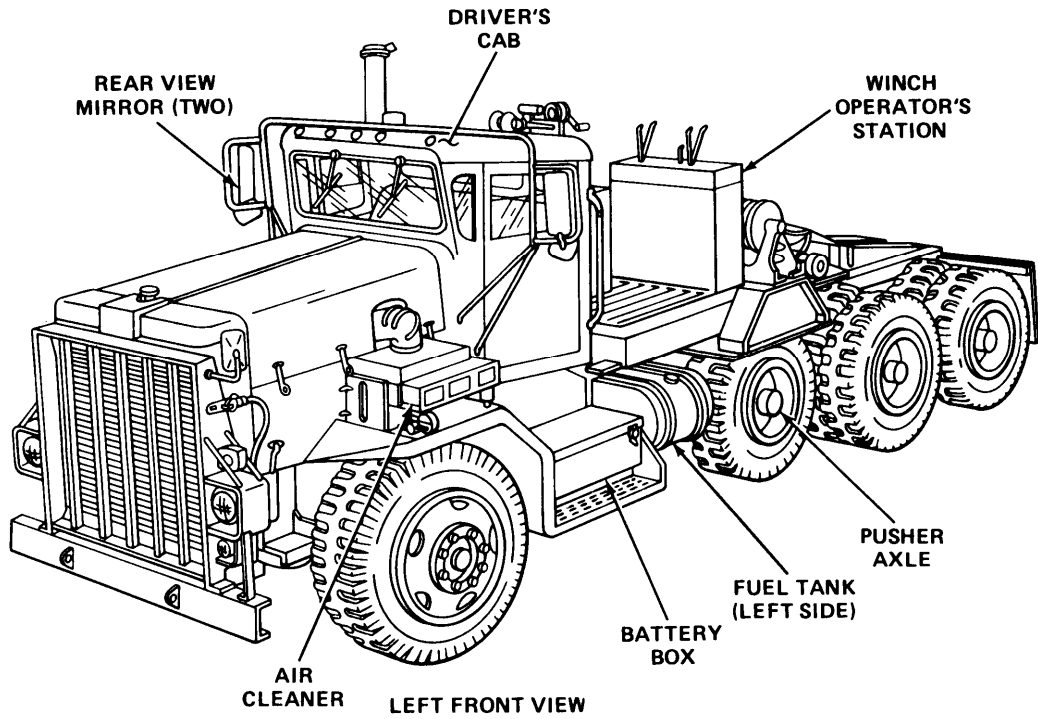

TA239579

CHAPTER 1

INTRODUCTION

OVERVIEW

This chapter contains data to familiarize you with the purpose and capabilities of the M911 Truck Tractor. It also contains a brief description of the M911 Truck Tractor systems and components.

	Page
Section I. General Information.....	1-1
Section II. Equipment Description and Data	1-2
Section III. Technical Principles of Operation	1-14

Section I. GENERAL INFORMATION

	Page	Page	
Destruction of Army Materiel to Prevent Enemy Use	1-2	Reporting Equipment Improvement Recommendations (EIR).....	1-2
Maintenance Forms and Records	1-1	Scope.....	1-1
Equipment Improvement Report and Maintenance Digest (EIR MD)	1-1	Warranty Information	1-2

SCOPE

Type of Manual: Organizational Maintenance.

Model Number and Equipment Name: M911 Truck Tractor, Commercial Heavy Equipment Transporter (C-H ET).

Purpose of Equipment: Used to pull C-HET Semitrailer.

MAINTENANCE FORMS AND RECORDS

Department of the Army forms and procedures used for equipment maintenance will be those prescribed by DA Pam 738-750, The Army Maintenance Management System (TAMMS).

EQUIPMENT IMPROVEMENT REPORT AND MAINTENANCE DIGEST (EIR MD)

The semiannual Equipment Improvement Report and Maintenance Digest, TB 43-0001-40 series, contains valuable field information on the equipment covered in this manual. The information in the TB 43-0001-40 series is compiled from some of the Equipment Improvement Reports that you prepared on the vehicles covered in this manual. Many of these articles result from comments, suggestions, and improvement recommendations that you submitted to the EIR program. The TB 43-0001-40 series contains information on equipment improvements, minor alterations, proposed Modification Work Orders (MWO'S), warranties (if applicable), actions taken on some of your DA Form 2028's (Recommended Changes to Publications), and advance information on proposed changes that may affect this manual. The information will help you in doing your job better and will help in keeping you advised of the latest changes to this manual. Also, refer to DA PAM 310-1 (Consolidated Index of Army Publications and Blank Forms) and Appendix A, References, of this manual.

DESTRUCTION OF ARMY MATERIEL TO PREVENT ENEMY USE

Refer to TM 750-244-6, Procedures for Destruction of Tank-Automotive Equipment to Prevent Enemy Use (US Army Tank-Automotive Command).

REPORTING EQUIPMENT IMPROVEMENT RECOMMENDATIONS (EIR)

If your M911 Truck Tractor needs improvement, let us know. Send us an EIR. You, the user, are the only one who can tell us what you don't like about your equipment. Let us know why you don't like the design. Put it on an SF 368 (Quality Deficiency Report). Mail it to us at Commander, US Army Tank-Automotive Command, AITN: AMSTA-QRT, Warren, MI 48397-5000. We will send you a reply.

WARRANTY INFORMATION

Refer to TB 9-2300-295-15/15 for the M911 Truck Tractor warranty information and data.

Section II. EQUIPMENT DESCRIPTION AND DATA

	Page		Page
Equipment Characteristics, Capabilities, and Features	1-2	Identification and Warranty Plates	1-6
Equipment Data	1-8	Location and Description of Major Components	1-6

EQUIPMENT CHARACTERISTICS, CAPABILITIES, AND FEATURES

The M911 Truck Tractor is used with the M747 Semitrailer to transport main battle tanks or similar vehicles.

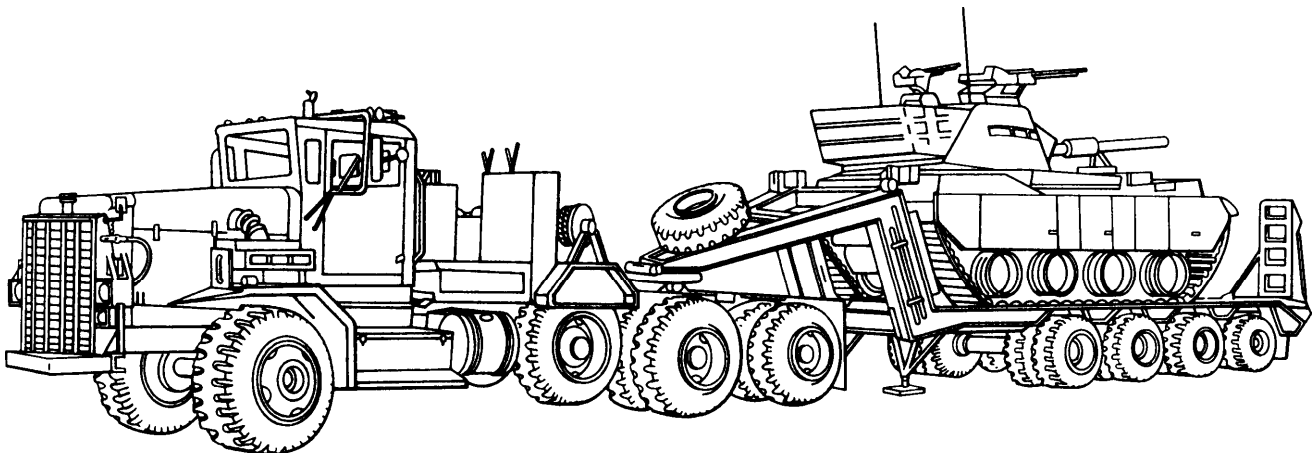

EQUIPMENT CHARACTERISTICS, CAPABILITIES, AND FEATURES - CONTINUED

The M911 Truck Tractor has a heat exchanger that cools the main transmission oil.

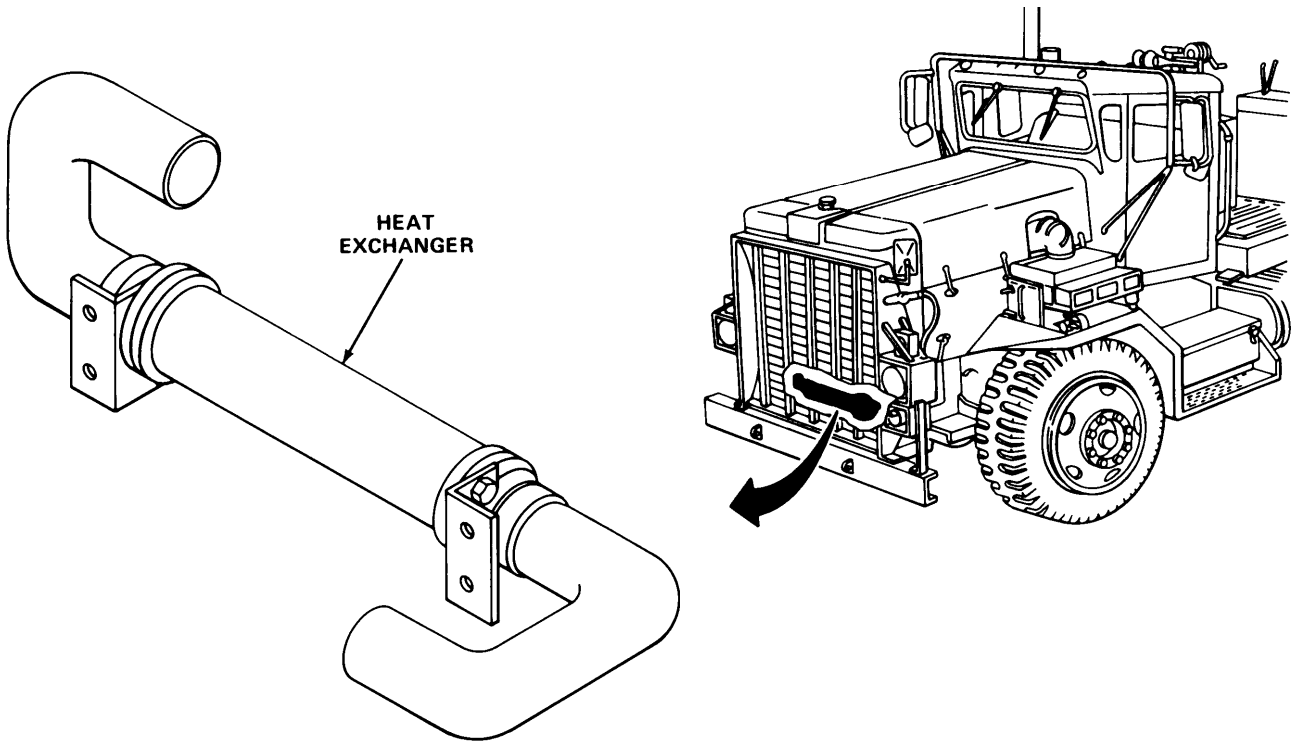

The M911 Truck Tractor has a gear type fuel pump that is driven by the engine.

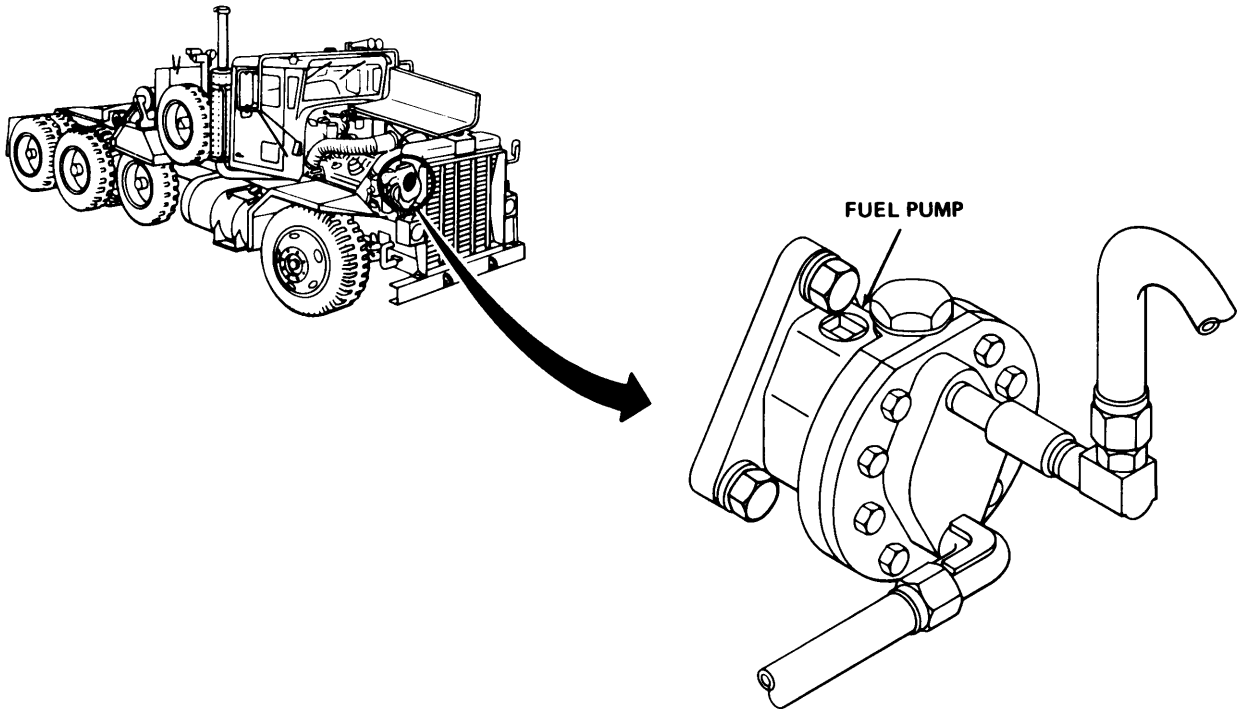

TA239581

EQUIPMENT CHARACTERISTICS, CAPABILITIES, AND FEATURES- CONTINUED

The M911 Truck Tractor has a conventional type power steering system with a hydraulic booster in the linkage.

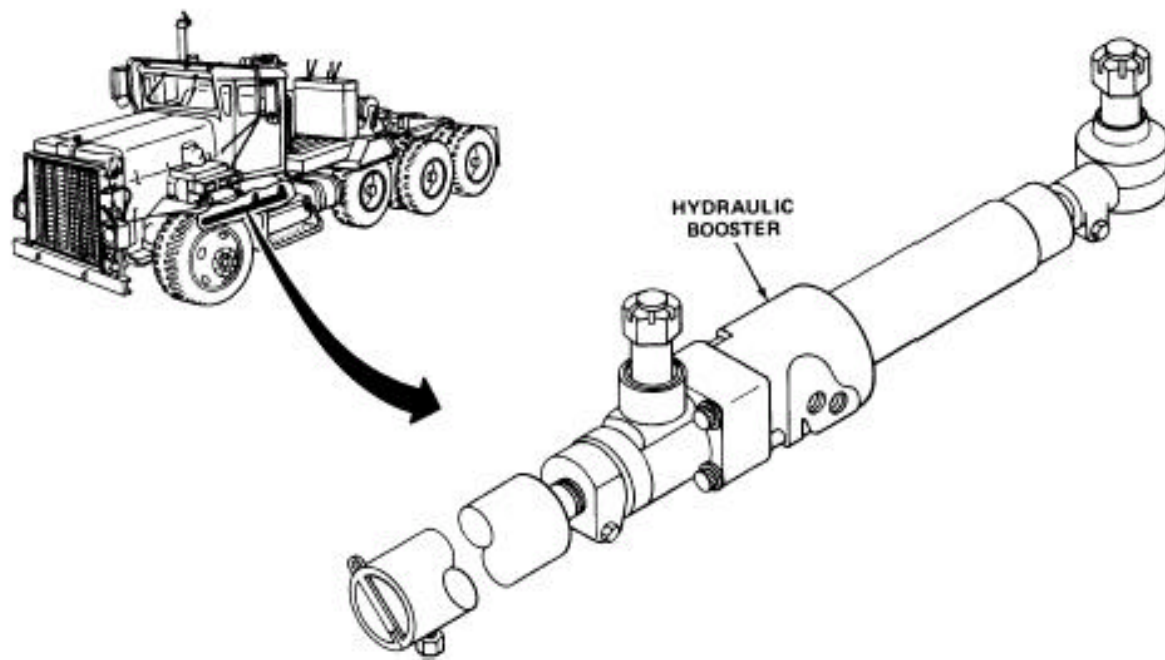

The M911 Truck Tractor has a five-speed automatic transmission.

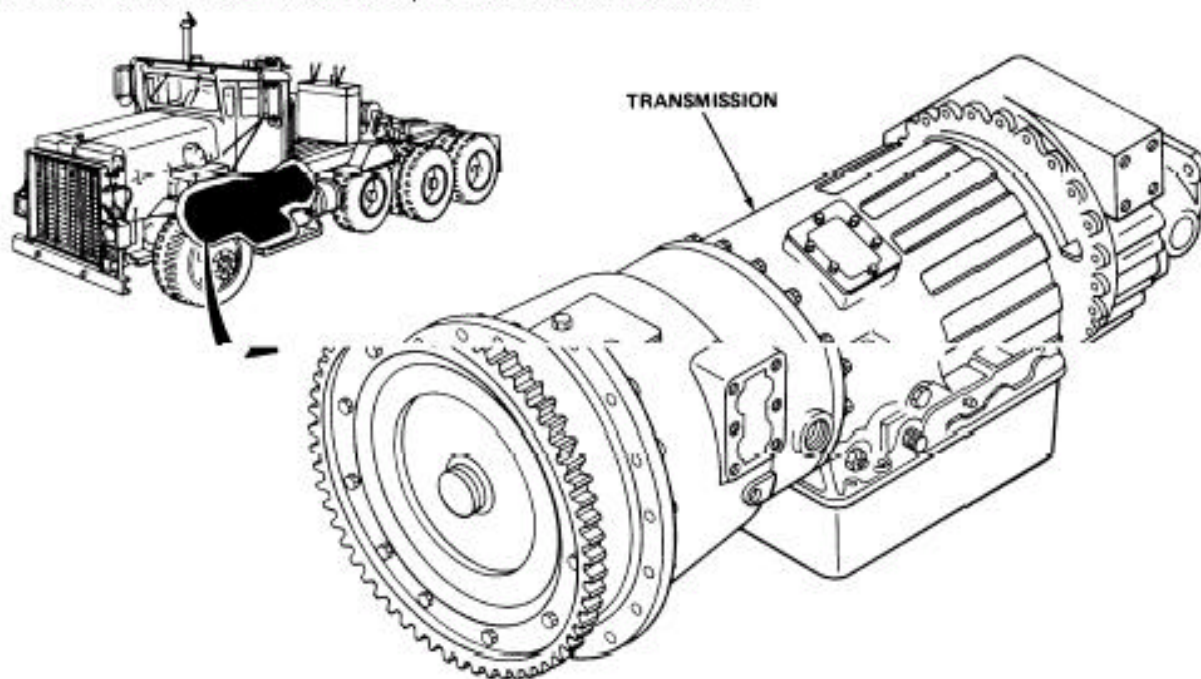

EQUIPMENT CHARACTERISTICS, CAPABILITIES, AND FEATURES - CONTINUED

The M911 Truck Tractor has a dual airbrake system operated by a dual airbrake valve.

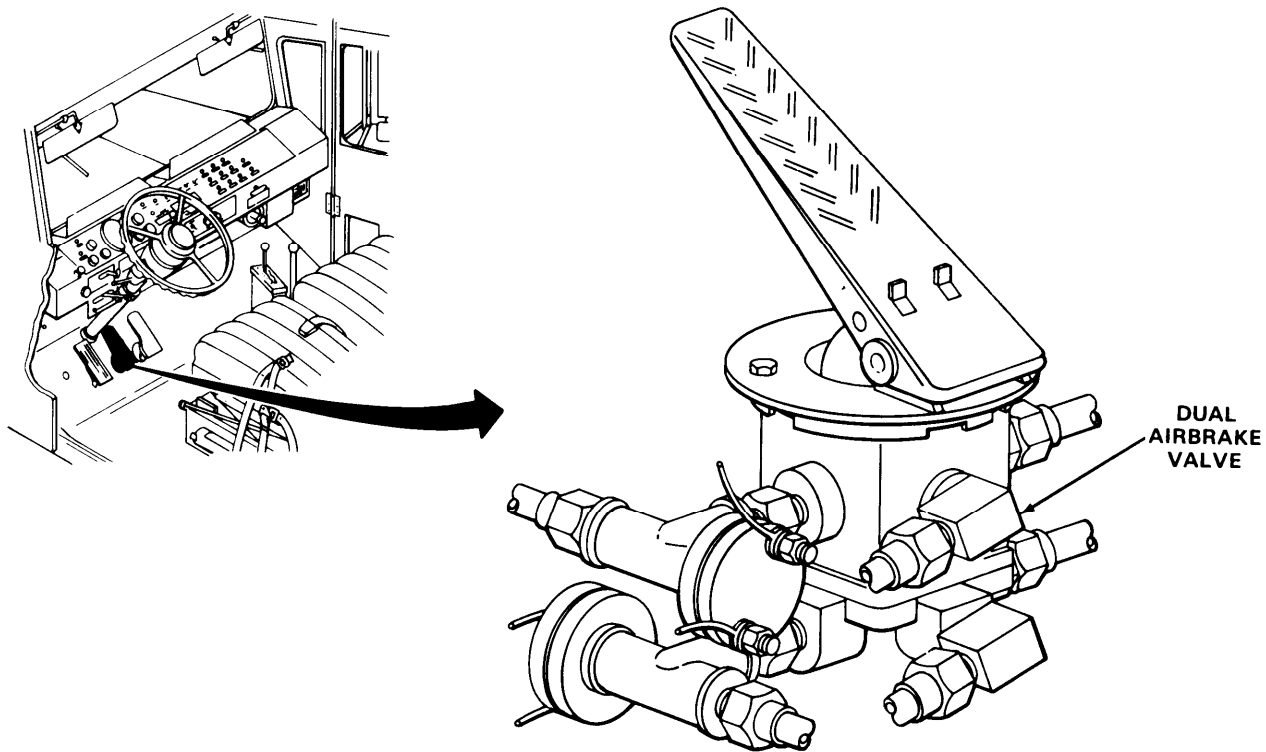

The M911 Truck Tractor has a pusher axle that can be lowered to distribute heavy payloads.

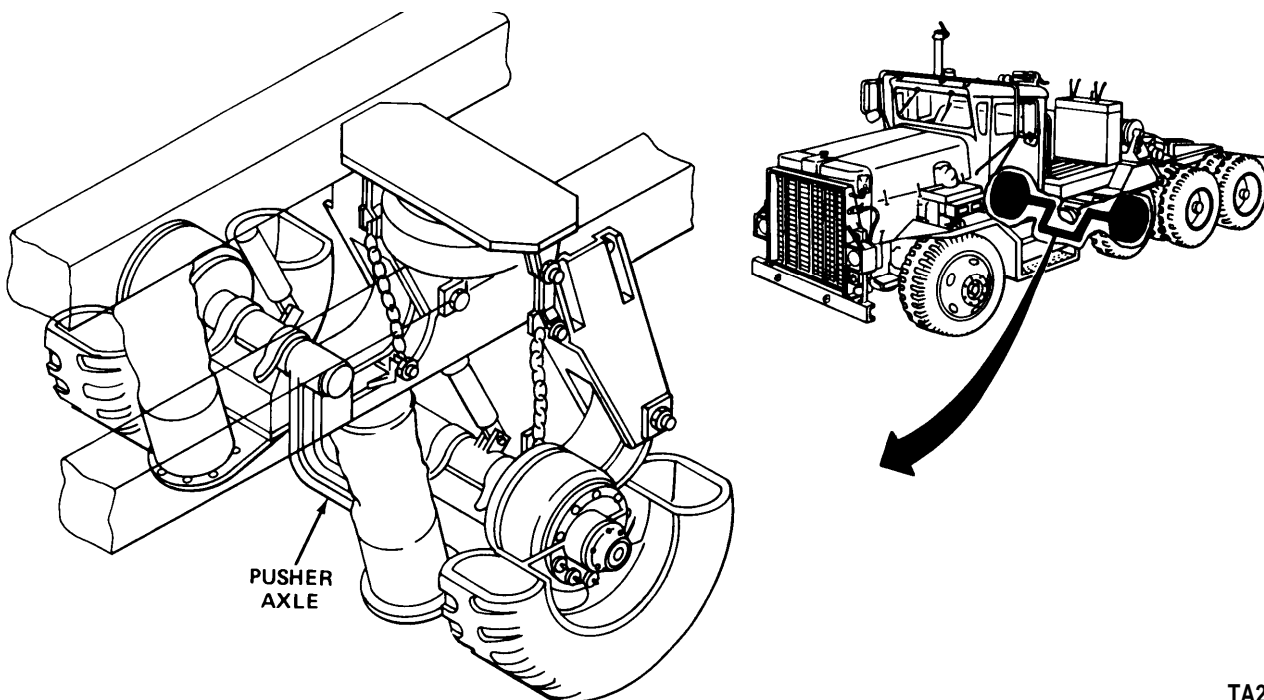

TA239583

EQUIPMENT CHARACTERISTICS, CAPABILITIES, AND FEATURES - CONTINUED

The M911 Truck Tractor has three drive axles.

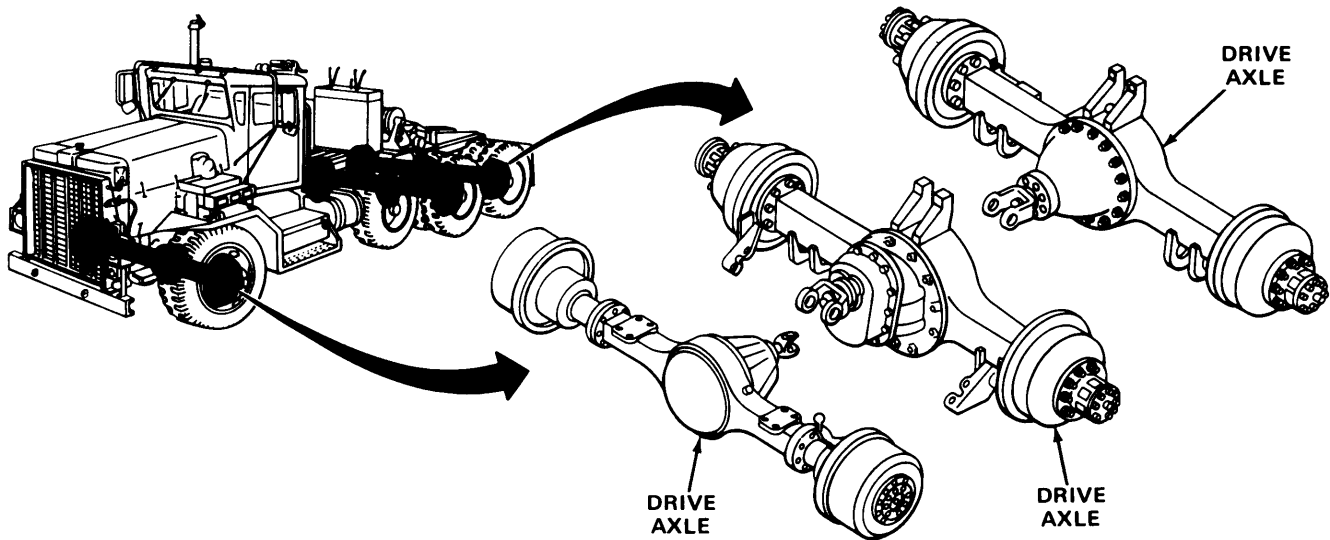

LOCATION AND DESCRIPTION OF MAJOR COMPONENTS

Passenger's Seat

The passenger's seat is a fixed, bench type seat assembly that can seat two crewmembers.

Operator's Seat

The operator's seat adjusts forward and backward. The seat backrest can be adjusted to three positions and a built-in shock absorber assembly adjusts to operator's weight.

IDENTIFICATION AND WARRANTY PLATES

Commercial Identification Plate

Gives identifying commercial equipment data for the M911 Truck Tractor

Military Identification Plate

Gives identifying commercial equipment data for the M911 Truck Tractor

Warranty Plate

Gives warranty information for the M911 Truck Tractor

IDENTIFICATION AND WARRANTY PLATES - CONTINUED

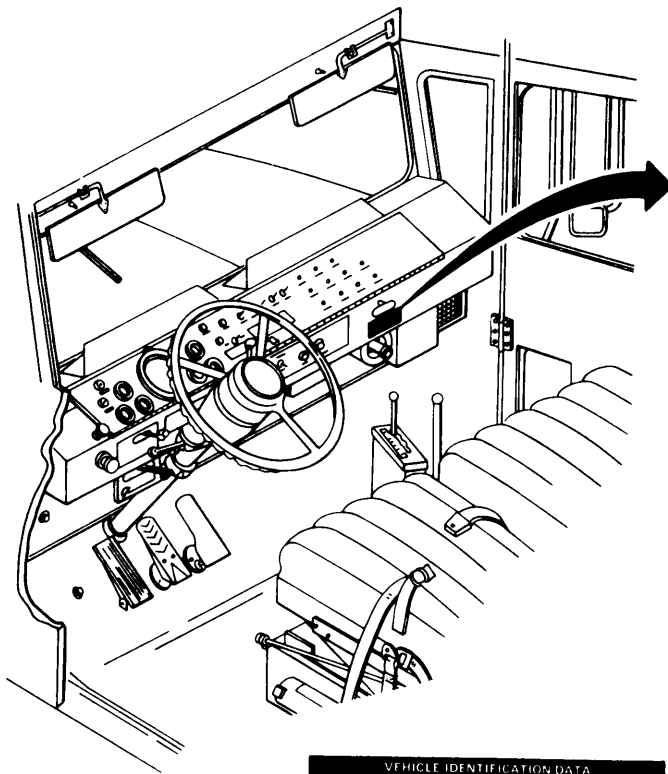

COMMERCIAL IDENTIFICATION PLATE

VEHICLE IDENTIFICATION DATA
 MODEL SERIAL NO.
 ENGINE GOV. SPEED RPM FULL LOAD
 AXLE MANUFACTURER'S HUB RATINGS (LESS WHEELS AND TIRES)
 FRONT AXLE LBS. (DRIVING)
 REAR AXLE LBS. (DRIVING)
 AIR SUSPENDED AXLE AXLE LBS. (FA)
 TOTAL COMBINATION OF HUB RATINGS NOT TO EXCEED LBS.

DEFLECTION AND DEFLECTING WILL VOID WARRANTY. SEE THE MANUFACTURER'S REPAIR PLATE FOR RATED LOAD LIMITS AT THE FABRIKATED POINTS OF THIS VEHICLE WITH WHEELS AND TIRES AS EQUIPPED AS ORIGINAL EQUIPMENT. FUTURE REPLACEMENT OF TIRES, WHEELS MUST NOT BE RATED ABOVE THE ABOVE AXLE WHEEL OR TIRE RATINGS.

MANUFACTURED UNDER THE FOLLOWING PATENTS
 UNITED STATES 4,252,000 4,002,000 3,957,000
 3,948,297 3,622,000 3,622,000
 3,111,228 3,622,000 3,622,000
 2,742,241 3,622,000 3,622,000
 2,709,962 3,622,000 3,622,000
 2,679,962

OTHER PATENT PENDING

OSHKOSH TRUCK CORP.
 OSHKOSH, WIS., U.S.A.

THIS ITEM WARRANTED FOR FIFTEEN (15) MONTHS OR 15,000 MILES, WHICHEVER OCCURS FIRST

WARRANTY BEGINS ON DATE OF GOVERNMENT ACCEPTANCE.

CONTRACT NUMBER DAAE07 76 C 4405.

REPORT FAILURES TO OSHKOSH TRUCK CORP., OSHKOSH, WI. 54901

WARRANTY PLATE

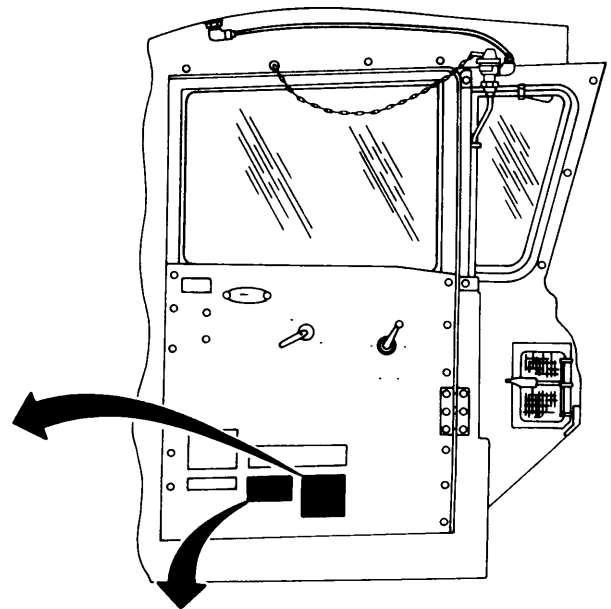

MILITARY IDENTIFICATION PLATE

VEHICLE IDENTIFICATION DATA
 MODEL MILITARY M911
 TYPE TRACTOR 8x6
 NSN 2320 01 025 3733
 CONTRACT NO. DAAE07 76 C 4405
 OSHKOSH SERIAL NO. _____
 DATE OF MFG. _____
 US ARMY REG. NO. _____
 ENGINE OOAD 8V 92T 90
 SERIAL NO. _____