

TECHNICAL MANUAL

OPERATOR'S, UNIT, AND
DIRECT SUPPORT MAINTENANCE MANUAL
AND REPAIR PARTS AND SPECIAL TOOLS LIST

This copy is a reprint which includes current pages from Changes 1 through 3.

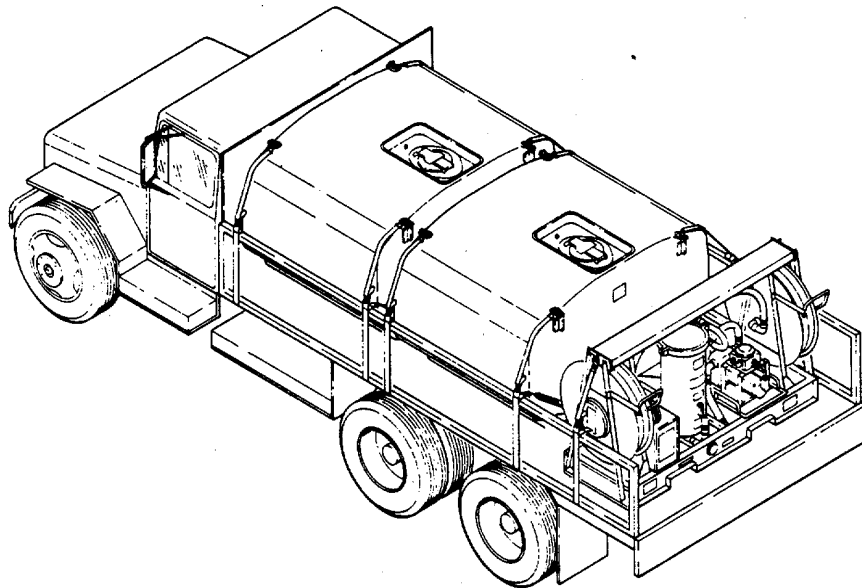

TANK AND PUMP UNIT,
LIQUID DISPENSING;
FOR TRUCK MOUNTING
MIL DESIGN TANK AND PUMP UNIT

ELECTRIC MOTOR DRIVEN
MODEL (97403) 13226E2150
NSN 4930-01-274-0212

OPERATING
INSTRUCTIONS
PAGE 2-1 -

OPERATOR PREVENTIVE
MAINTENANCE CHECKS
AND SERVICES
PAGE 2-5

OPERATOR MAINTENANCE
INSTRUCTIONS
PAGE 3-1

UNIT MAINTENANCE
INSTRUCTIONS
PAGE 4-1

UNIT TROUBLESHOOTING
PAGE 4-10

DIRECT
SUPPORT MAINTENANCE
INSTRUCTIONS
PAGE 5-1

DIRECT SUPPORT
TROUBLESHOOTING I
PAGE 5-1

ALPHABETICAL INDEX
PAGE INDEX-1

Approved for public release; distribution is unlimited.

HEADQUARTERS, DEPARTMENT OF THE ARMY
30 AUGUST 1991

OPERATOR'S, UNIT, AND
DIRECT SUPPORT MAINTENANCE MANUAL
AND REPAIR PARTS AND SPECIAL TOOLS LIST

**TANK AND PUMP UNIT,
LIQUID DISPENSING;
FOR TRUCK MOUNTING
MIL DESIGN TANK AND PUMP UNIT
ELECTRIC MOTOR DRIVEN
MODEL (97403) 13226E2150
NSN 4930-01-274-0021**

Current as of 14 August 1991.

Approved for public release; distribution is unlimited.

REPORTING ERRORS AND RECOMMENDING IMPROVEMENTS

You can help improve this manual. If you find any mistake or if you know of a way to improve the procedures, please let us know. Mail your letter, DA Form 2028 (Recommended Changes to Publications and Blank Forms), or DA Form 2028-2 located in the back of this manual direct to: Commander, U.S. Army Troop Support Command, ATTN: AMSTR-MMTS, 4300 Goodfellow Boulevard, St. Louis, MO 63120-t798. A reply will be furnished directly to you.

		Page
CHAPTER	1. INTRODUCTION	1-1
Section	I. General Information	1-1
Section	II. Equipment Description and Data	1-2
Section	III. Technical Principles of Operation	1-6
CHAPTER	2. OPERATING INSTRUCTION.....	2-1
Section	I. Description and Use of Operator's Controls and Indicators	2-1
Section	II. Operator Preventive Maintenance Checks and Services (PMCS)	2-5
Section	III. Operation Under Usual Conditions	2-12
Section	IV. Operation Under Unusual Conditions	2-25

CHAPTER	3.	OPERATOR MAINTENANCE INSTRUCTIONS	3-1
Section	I.	Lubrication Instructions	3-1
Section	II.	Troubleshooting	3-1
Section	III.	Maintenance Procedures	3-3
CHAPTER	4.	UNIT MAINTENANCE INSTRUCTIONS	4-1
Section	I.	Repair Parts, Special Tools, TMDE and Support Equipment	4-1
Section	II.	Service Upon Receipt	4-1
Section	III.	Preventive Maintenance Checks and Services	4-7
Section	IV.	Troubleshooting	4-10
Section	V.	Maintenance Procedures	4-12
Section	VI.	Preparation for Shipment or Storage	4-67
CHAPTER	5.	DIRECT SUPPORT MAINTENANCE INSTRUCTIONS	5-1
Section	I.	Repair Parts, Special Tools, TMDE and Support Equipment	5-1
Section	II.	Troubleshooting	5-1
Section	III.	Maintenance Procedures	5-3
APPENDIX	A.	REFERENCES	A-1
APPENDIX	B.	MAINTENANCE ALLOCATION CHART	B-1
Section	I.	Introduction	B-1
Section	II.	Maintenance Allocation Chart.....	B-4
Section	III.	Tools and Test Equipment Requirements	B-7
Section	IV.	Remarks	B-8
APPENDIX	C.	COMPONENTS OF END ITEM LIST (COEIL)	C-1
APPENDIX	D.	ADDITIONAL AUTHORIZATION LIST (ML)	D-1
APPENDIX	E.	EXPANDABLE/DURABLE SUPPLIES AND MATERIALS LIST	E-1
APPENDIX	F.	REPAIR PARTS AND SPECIAL TOOLS LIST	F-1

		PAGE	FIGURE NO.
Section	I.	Introduction	F-1
Section	II.	Repair Parts List	F-1
Group	01.	Pump Unit, Liquid Dispensing	
		0101 Hoses and Static Reel	F-8 1
		0102 Fuel Dispensing Nozzle Assembly	F-10 2
		0103 Reel Assembly, Liquid Dispensing RH and LH	F-12 3
		0104 Filter Separator	F-14 4
		0105 EMD Pump Assembly	F-16 5
		0105 Junction Box Assembly	F-19 6
		0105 Pump Assembly	F-24 7
		0105 Electric Motor With Frame and Bracket.....	F-26 8
		0106 Valve Operating Lever Assembly	F-28 9
		0107 Quick Disconnect Adapter Half	F-30 10

HOW TO USE THIS MANUAL

Spend a few minutes looking through this manual. It has a new look that is very different from the manuals you've been using. You'll find the new look is a lot easier to use, and you can find what you're looking for a lot faster.

Each chapter begins with an index that lists each paragraph or section in the chapter. Each section in the maintenance chapter also has an index that lists the procedures in the section and gives page numbers. Or you can look for the information you want in the alphabetical subject index at the back of this manual.

We got rid of as many words as we could and put in lots of illustrations to show just about everything you'll be doing to maintain your equipment.

The text is keyed to the illustration with callous numbers (sometimes words). The callous numbers are in parentheses in the text.

So, HOW DO YOU USE THIS MANUAL?

Like This:

1. Suppose the electric motor won't operate and you want to troubleshoot the unit.
2. Look at the cover and you'll see index boxes near the right-hand edge with subject titles in them. You'll find "UNIT TROUBLESHOOTING 4-9". You can skip over to page 4-9.

OR

3. Bend the pages a bit and look at the edges. You'll see black bars on some of the pages that are lined up with the index boxes on the cover.
4. If you put your thumbnail on the black bar that is lined up with the box on the cover for UNIT TROUBLESHOOTING and open the manual, you'll be on page 4-9.
5. On page 4-9, you'll find Section IV, TROUBLESHOOTING.
6. Turn to page 4-10 and find the symptom "ELECTRIC MOTOR WON'T OPERATE".
7. As you do the tests and corrective actions in the order listed, you will get to replace power cable. Refer to paragraph 4-15.
8. Turn to paragraph 4-15 and look at the procedure. The "INITIAL SETUP" section tells you what tools, materials, and parts are needed to do this task. It also tells you anything you must do before starting this task and it gives general warnings about hazards that can exist while you do this task.
9. The procedure itself has a picture to show you where to look and what to look at, plus the steps you will do to perform the task.
10. Notice the numbered arrows. These are the callous numbers. As you read each step, we tell you where to look by including the callous number (in parentheses) after the name of each thing we call out.
11. Do the procedure, then check to see if you have corrected the fault symptom.

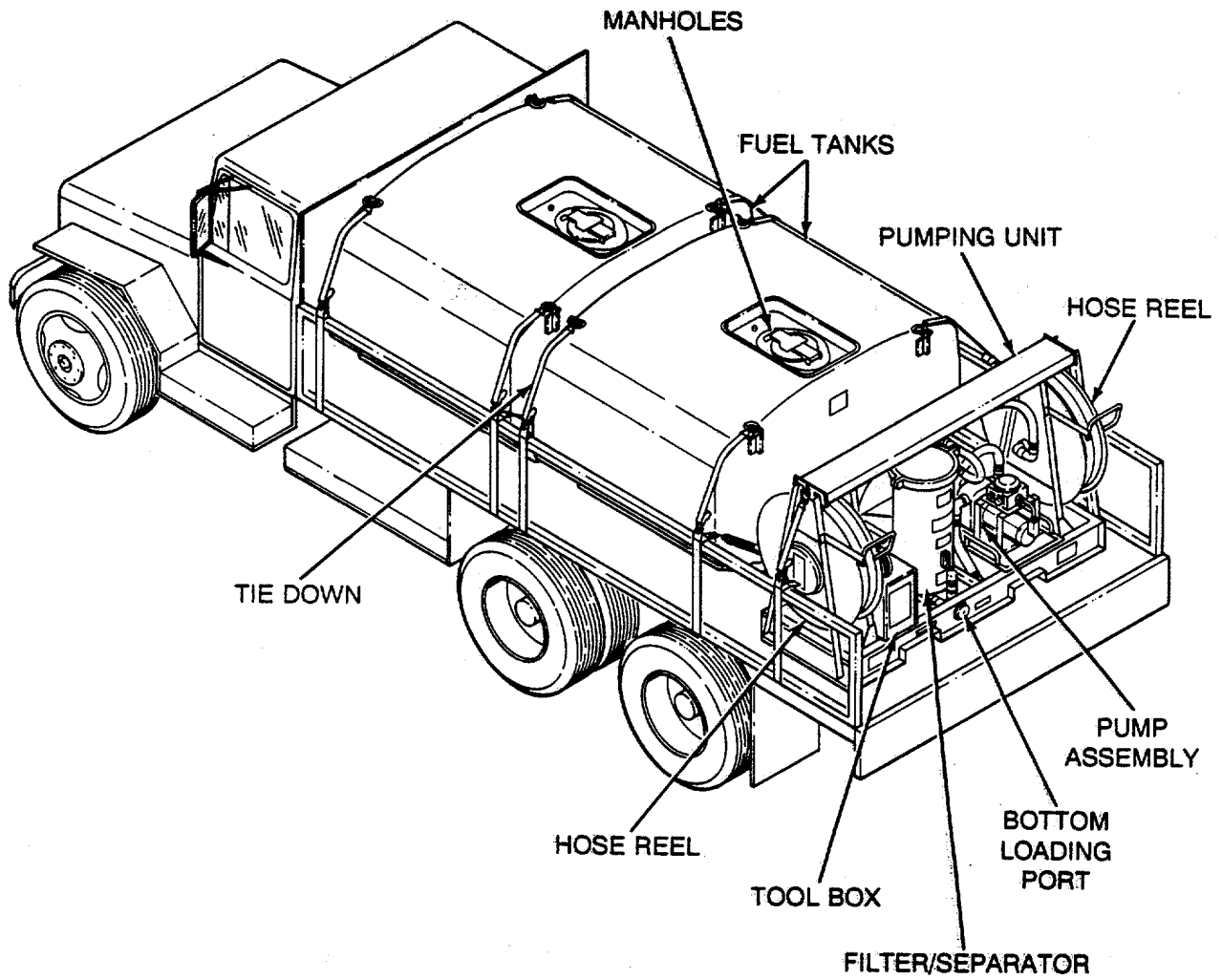

CHAPTER 1
INTRODUCTION

	Page
Section I. General Information	1-1
Section II. Equipment Description and Data	1-2
Section III. Technical Principles of Operation	1-6

SECTION I. GENERAL INFORMATION

Paragraph	Page
1-1 Scope	1-1
1-2 Maintenance Forms and Records	1-1
1-3 Hand Receipt (-HR) Manual	1-1
1-4 Reporting Equipment Improvement Recommendations (EIR)	1-1
1-5 Destruction of Army Material to Prevent Enemy Use	1-1
1-6 Preparation for Storage or Shipment	1-1
1-7 Warranty Information	1-2

1-1. Scope.

a. Type of Manual This manual provides Operator's, Unit, Direct Support Maintenance Manual, and Repair Parts and Special Tools List for the Tank and Pump Unit, Liquid Dispensing: for Truck Mounting, MIL Design Tank and Pump Unit, Electric Motor Driven Model 13226E2150.

b. Purpose of Equipment The purpose of the tank and pump unit is to provide mobile refueling unit for dispensing fuel to military vehicles.

1-2. Maintenance Forms and Records. Department of the Army forms and procedures used for equipment maintenance will be those prescribed by DA PAM 738-750 The Army Maintenance Management System (TAMMS).

1-3. Hand Receipt (-HR) Manual. This manual has a companion document with a TM number followed by -HR (which stands for Hand Receipt) The TM10-g3-236---HR consists of preprinted hand receipts (DA Form 2062) that list end item related equipment (i.e. COEI, BIL, and ML) you must account for As an aid to property accountability, additional -HR manuals may be requisitioned from the following source in accordance with procedures in AR25-30.

1-4. Reporting Equipment Improvement Recommendations (EIR). If your tank and pump unit needs improvement, let us know Send us an EIR You, the user, are the only one who can tell us what you don't like about your equipment. Let us know why you don't like the design or performance Put it on an SF 368, Quality Deficiency Report Mail it to us at Commander, US Army Troop Support Command, ATTIC AMSTR-MOF, 4300 Goodfellow Blvd., St. Louis, Missouri 63120-1798. We will send you a reply.

1-5. Destruction of Army Material to Prevent Enemy Use. Demolition of material to prevent enemy use will be in accordance with the requirements of TM 750-244-3, Procedures for Destruction of Equipment to Prevent Enemy Use.

1-6. Preparation for Storage or Shipment. Refer to Chapter 4, Section VI to place equipment into storage and for procedures to place equipment into administrative storage.

1-7. Warranty Information. The Tank and Pump Unit is not covered by warranty.

SECTION II. EQUIPMENT DESCRIPTION AND DATA

Paragraph		Page
1-8	Equipment Characteristics, Capabilities and Features	1-2
1-9	Location and Description of Major Components	1-2
1-10	Equipment Data	1-5
1-11	Safety, Care and Handling	1-6

1-8. Equipment Characteristics, Capabilities and Features.

a. Characteristics. The tank and pump unit consists of one electric motor driven 50 gpm (189 liters per minute) pumping assembly, two 500-gallon (1892.5 liter) tanks and related items. It is designed for use with M-34, M-3S, M-36, M-41, M-54, M-55, M-135, M-211, M-923, M-924, M-925 and M-926 vehicles.

b. Capabilities and Features.

- (1) Self priming pump.
- (2) All weather operational.
- (3) Used to convert cargo truck to bulk fuel carrier/dispenser.
- (4) Automatic fuel shutoff during bottom loading refilling.

1-9. Location and Description of Major Components. The following paragraphs contain a functional description of the major components of the tank and pump unit. The location and appearance of the major components are illustrated. The numbers following the nomenclature of the major component correspond to the index numbers in the illustration.

a. **A-FRAME (1).** Provides a housing and supports for the assembled components of the pumping unit. The base of the frame is designed to facilitate loading, transporting, and unloading the pumping unit with a forklift.

b. **INTERVEHICLE POWER CABLE (2).** Provides electrical connection between the NATO slave receptacle on the vehicle and the electric motor for driving the pump.

c. **VEHICLE NATO SLAVE RECEPTACLE (3).** This receptacle is mounted on the back of the truck cab. It provides a means for connecting the truck electrical system to the pumping unit.

d. **NATO ADAPTER (4).** Used to make a compatible connection between the intervehicle power cable and the vehicle NATO slave receptacle.

e. **HOSE REEL (5).** There are two hose reels on the pumping unit. The hose reels are used to retain the hoses in a stowed position, when the pumping unit is not in operation.