

TM 11-6625-623-40P

TECHNICAL MANUAL

**GENERAL SUPPORT MAINTENANCE REPAIR PARTS AND SPECIAL TOOLS LISTS
FOR**

**MAINTENANCE KIT, ELECTRONIC EQUIPMENT MK-722/URC
(NSN 6625-00-082-4275**

HEADQUARTERS, DEPARTMENT OF THE ARMY

JULY 1978

TECHNICAL MANUAL }
 NO.11-6625-623-40P }

HEADQUARTERS
 DEPARTMENT OF THE ARMY
 WASHINGTON, DC, 25 July 1978

**GENERAL SUPPORT MAINTENANCE REPAIR PARTS AND SPECIAL TOOLS LISTS
 FOR
 MAINTENANCE KIT, ELECTRONIC EQUIPMENT MK-722/URC
 (NSN 6625-00-082-4275)**

Current as of 15 February 1978

REPORTING OF ERRORS

You can improve this manual by recommending improvements using DA Form 2028 -2 located in the back of the manual. Simply tear out the self addressed form, fill it out as shown on the sample, fold it where shown, and drop it in the mail.

If there are no blank DA Forms 2028-2 in the back of your manual, use the standard DA Form 2028 (Recommended Changes to Publications and Blank Forms) and forward to the Commander, US Army Communications and Electronics Materiel Readiness Command, ATTN: DRSEL-MA - Q, Fort Monmouth, New Jersey 07703.

In either case a reply will be furnished direct to you.

Table of Contents

		Page	Illus Figure
SECTION	I. Introduction	1	
	II. Repair parts list	5	
GROUP	00 Maintenance Kit, Electronic Equipment MK-722/URC (I)	5	1
	01 Extender Module MX-4890/URC (IA1)	9	2
	02 Extender Module MX-4888/URC (IA2)	11	3
	03 Extender Module MX-4892/URC (IA3)	13	4
	0301 Intermediate frequency translator load (IA3A1)	15	5
	04 Extender Module MX-4895/URC (IA4)	17	6
	05 Extender Module MX-4894/URC (IA5)	19	7
	06 Extender Module MX-4893/URC (IA6)	21	8
	07 Extender Module MX-4891/URC (IA7)	23	9
	08 Extender Module MX-4889/URC (IA10)	25	10
	09 Extender Module MX-4887/URC (IA12)	27	11
	10 Attenuator, Fixed CN-1066/URC (IA14)	31	12
	11 Voltage Divider TS-1955/URC (IA15)	33	13
	12 Voltage Divider TS-1954/URC (IA16)	35	14
	13 Dummy Load, Electrical DA-340/URC (IA17)	37	15
	14 Detector, Radio Frequency DT-278/URC (IA18)	39	16
	15 Cable Assembly, Radio Frequency CG-3126/U (IA20)	41	17
	16 Cable Assembly, Radio Frequency CG-409G/U4in (IA21 through IA26)	41	17
	17 Cable Assembly, Radio Frequency CG-2727/U5ftOin (IA27)	41	17
	18 Maintenance Fixture MT-3039/URC (IA28)	43	18
	19 Test Set, Radio TS-1956/URC (IA32)	45	19
	1901 Test set, function (IA32A1)	47	20
	190101 Test set subassembly (IA32A1A1)	51	21
	190102 Test set subassembly (IA32A1A2)	53	22
	1902 Cable Assembly, Power CX-9009/URC (IA32W7)	55	23
SECTION	III. Special tools list (Not applicable)		
	IV. National stock number and part number index	56	

*This manual supersedes TM 11-6625-623-35P, 5 December 1969.

SECTION I

INTRODUCTION

1. Scope

This manual lists spares and repair parts; special tools, special test, measurement, and diagnostic equipment (TMDE), and other special support equipment required for performance of general support maintenance of the MK-722/URC. It authorizes the requisitioning and issue of spares and repair parts as indicated by the source and maintenance codes.

2. General

This Repair Parts and Special Tools list is divided into the following sections:

a. *Section II. Repair Parts Lists.* A list of spares and repair parts authorized for use in the performance of maintenance. The list also includes parts which must be removed for replacement of the authorized parts. Parts list are composed of functional groups in numeric sequence, with the parts in each group listed in figure and item number sequence.

b. *Section III. Special Tools List.* Not applicable.

c. *Section IV National Stock Number and Part Number Index.* A list, in National item identification number (NIIN) sequence, of all National stock numbers (NSN) appearing in the listings, followed by a list, in alphanumeric sequence, of all part numbers appearing in the listings. National stock numbers and part numbers are cross-referenced to each illustration figure and item number appearance.

3. Explanation of Columns

a. *Illustration.* This column is divided as follows:

(1) *Figure number.* Indicates the figure number of the illustration on which the item is shown.

(2) *Item number.* The number used to identify item called out in the illustration.

b. *Source, Maintenance, and Recoverability (SMR) codes.*

(1) *Source code.* Source codes indicate the manner of acquiring support items for maintenance, repair, or overhaul of end items. Source codes are entered in the first and second positions of the Uniform SMR Code format as follows:

code

Definition

PA — Item procured and stocked for anticipated or known usage.

XD — A support item that is not stocked. When required, item will be procured through normal supply channels.

NOTE

Cannibalization or salvage may be used as a source of supply for any items source coded above except those coded XA and aircraft support items as restricted by AR 700-42.

(2) *Maintenance code.* Maintenance codes are assigned to indicate the levels of maintenance authorized to USE and REPAIR support items. The maintenance codes are entered in the third and fourth positions of the Uniform SMR Code format as follows:

(a) The maintenance code entered in the third position will indicate the lowest maintenance level authorized to remove, replace, and use the support item. The maintenance code entered in the third position will indicate one of the following levels of maintenance.

Code

Application/Explanation

O — Support item is removed, replaced, used at the organizational level.

H — Support item is removed, replaced, used at the general support level.

(b) The maintenance code entered in the fourth position indicates whether the item is to be repaired and identifies the lowest maintenance level with the capability to perform complete repair (i.e., all authorized maintenance functions). This position will contain one of the following maintenance codes:

Code

Application/Explanation

H — The lowest maintenance level capable of com-

<i>Code</i>	<i>Application/Explanation</i>
	plete repair of the support item is the general support level.
Z	—Nonreparable. No repair is authorized.

(3) *Recoverability code.* Recoverability codes are assigned to support items to indicate the disposition action on unserviceable items. The recoverability code is entered in the fifth position of the Uniform SMR Code format as follows:

<i>Recoverability code</i>	<i>Definition</i>
Z	— Nonreparable item. When unserviceable, condemn and dispose at the level indicated in position 3.
H	— Repairable item. When uneconomically repairable, condemn and dispose at the general support level.

c. *National Stock Number.* Indicates the National stock number assigned to the item and will be used for requisitioning purposes.

d. *Part Number.* Indicates the primary number used by the manufacturer (individual, company, firm, corporation, or Government activity), which controls the design and characteristics of the item by means of its engineering drawings, specifications, standards, and inspection requirements to identify an item or range of items.

NOTE

When a stock numbered item is requisitioned, the repair part received may have a different part number than the part being replaced.

e. *Federal Supply Code for Manufacturer (FSCM).* The FSCM is a f-digit numeric code listed in SB 708-42 which is used to identify the manufacturer, distributor, or Government agency, etc.

f. *Description.* Indicates the Federal item name and, if required, a minimum description to identify the item.

g. *Unit of Measure (U/M).* Indicates the standard of the basic quantity of the listed item as used in performing the actual maintenance function. This measure is expressed by a two-character alphabetical

abbreviation (e.g., ea, in, pr, etc). When the unit of measure differs from the unit of issue, the lowest unit of issue that will satisfy the required units of measure will be requisitioned.

h. *Quantity Incorporated in Unit.* Indicates the quantity of the item used in the breakout shown on the illustration figure, which is prepared for a functional group, subfunctional group, or an assembly.

4. Special Information

The following publications pertain to the MK-722/URC and its components:

- TM 11-6625-623-12, Maintenance Kit, Electronic Equipment MK-722/URC
- TM 11-6625-623-20P, Maintenance Kit, Electrical Equipment MK-722/URC
- TM 11-6625-623-45, Maintenance Kit, Electronic Equipment MK-722/URC

5. How to Locate Repair Parts

a. When National stock number or part number is unknown.

(1) *First.* Using the table of contents, determine the functional group within which the item belongs. This is necessary since illustrations are prepared for functional groups and listings are divided into the same groups.

(2) *Second.* Find the illustration covering the functional group to which the item belongs.

(3) *Third.* Identify the item on the illustration and note the illustration figure and item number of the item.

(4) *Fourth.* Using the Repair Parts Listing, find the figure and item number noted on the illustration.

b. When National stock number or part number is known.

(1) *First.* Using the Index of National Stock Numbers and Part Numbers, find the pertinent National stock number or part number. This index is in NIIN sequence followed by a list of part numbers in alphameric sequence, cross-referenced to the illustration figure number and item number.

(2) *Second.* After finding the figure and item number, locate the figure and item number in the repair parts list.

6. Abbreviations

Not applicable.

(Next printed page is 4.1)

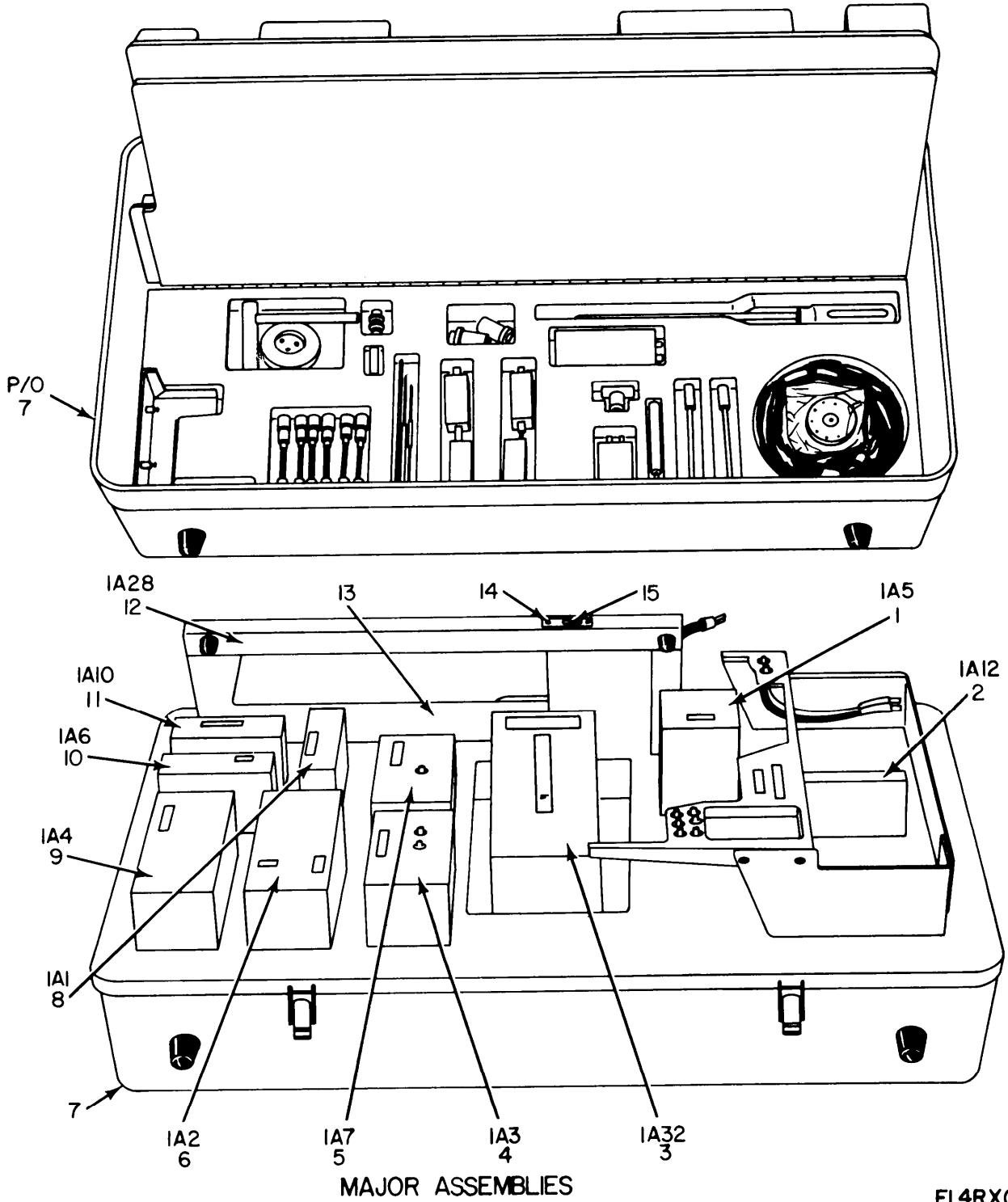

Figure 1. Maintenance Kit, Electronic Equipment MK-722/URC (1) (Sheet 1 of 2).