

**TM 11-6625-3081-23-2**

**TECHNICAL MANUAL  
ORGANIZATIONAL AND DIRECT SUPPORT  
MAINTENANCE MANUAL  
FOR  
ELECTRONIC EQUIPMENT TEST FACILITY  
TADS/PNVS AUGMENTATION EQUIPMENT  
13082808-39, 13231600, 13231650 AND 13231800  
WIRING DATA**

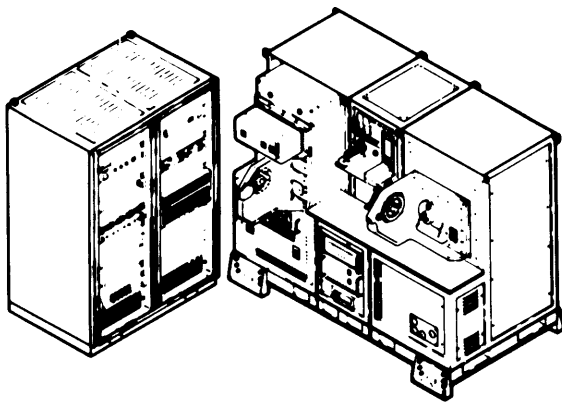

**ELECTRONIC STATION TO ELECTRO-OPTICAL  
TEST BENCH SET INTERCONNECTION (P 3-3)**

**ELECTRONIC STATION (P 3-6)**

**ELECTRO-OPTICAL TEST BENCH  
INTERCONNECTION (P3-35)**

**DAYSIDE TEST BENCH 2A1 (P 3-71)**

**TEST CONSOLE TEST BENCH 2A2 (P 3-151)**

**NIGHTSIDE TEST BENCH 2A3 (P 3-280)**

**"Approved for public release; distribution is unlimited."**

**This copy is a reprint which includes current  
pages from Changes 1 through 18**

**HEADQUARTERS, DEPARTMENT OF THE ARMY**

**1 FEBRUARY 1986**

ORGANIZATIONAL AND DIRECT SUPPORT  
 MAINTENANCE MANUAL  
 FOR  
 ELECTRONIC EQUIPMENT TEST FACILITY  
 TADS/PNVS AUGMENTATION EQUIPMENT

REPORTING ERRORS AND RECOMMENDING IMPROVEMENTS

You can help improve this manual. If you find any mistakes or if you know of a way to improve the procedures, please let us know. Mail your letter, DA Form 2028 (Recommended Changes to Publications and Blank Forms), or DA Form 2028-2 located in the back of this manual direct to: Commander, U. S. Army Aviation and Troop Command, ATTN: AMSAT-I-MP, 4300 Goodfellow Blvd, St. Louis, MO 63120-1798. A reply will be furnished to you.

DISTRIBUTION STATEMENT A: Approved for public release; distribution is unlimited

	Page
CHAPTER 3. WIRING DATA . . . . .	3-1
Section I. Repair Parts; Special Tools; Test, Measurement, and Diagnostic Equipment (TMDE); and Support Equipment . . . . .	3-2
II. Electronic Station to Electro-Optical Test Bench Set Interconnection Wiring Data . . . . .	3-3
III. Electronic Station Wiring Data . . . . .	3-6
IV. Electro-Optical Test Bench Set Interconnection Wiring Data . . . . .	3-35
V. Dayside Test Bench 2A1 Wiring Data . . . . .	3-71
VI. Test Console Test Bench 2A2 Wiring Data . . . . .	3-151
VII. Nightside Test Bench 2A3 Wiring Data . . . . .	3-280

LIST OF ILLUSTRATIONS

Figure	Title	
F0-32	System Interconnection Diagram . . . . .	F0-39
F0-33	AC Power Distribution Diagram . . . . .	F0-41
F0-34	DC Power Distribution Diagram . . . . .	F0-43
F0-35	Laser Interlock Circuit Diagram . . . . .	F0-53
F0-36	Electronic Station Interconnection Diagram . . . . .	F0-55
F0-37	Dayside Test Bench 2A1 Interconnection Diagram . . . . .	F0-57
F0-38	Optical Signal Analyzer 2A1A1 . . . . .	F0-59
F0-39	Test Console Test Bench 2A2 Interconnection Diagram . . . . .	F0-61
F0-40	Nightside Test Bench 2A3 Interconnection Diagram . . . . .	F0-63

## CHAPTER 3

## WIRING DATA

	Section	Page
Repair Parts; Special Tools; Test, Measurement, and Diagnostic Equipment (TMDE); and Support Equipment . . . . .	I	3-2
Electronic Station to Electro-Optical Test Bench Set Interconnection Wiring Data . . . . .	II	3-3
Electronic Station Wiring Data . . . . .	<b>III</b>	3-6
Electro-Optical Test Bench Set Interconnection Wiring Data . . . . .	IV	3-35
Dayside Test Bench 2A1 Wiring Data . . . . .	V	3-71
Test Console Test Bench 2A2 Wiring Data . . . . .	VI	3-151
Nightside Test Bench 2A3 Wiring Data . . . . .	VII	3-280
Test Program Sets Wiring Data . . . . .	VIII	3-309

## OVERVIEW

This chapter provides wiring data that covers both the electronic station and electro-optical test bench set. This includes interconnection diagrams and wire lists. Cable assemblies are listed in order by reference designator and part number.

This chapter also provides wiring data for the test program sets (TPS). This includes wire lists for the major test adapter UUT cable assemblies, self-test connectors, and test fixtures each covered in part number sequence.

Refer to system interconnection diagram (FO-32), AC power distribution diagram (FO-33), DC power distribution diagram (FO-34), and Laser interlock circuit diagram (FO-35), at the end of this volume for supplementary troubleshooting data for the EETF TADS/PNVS Augmentation Equipment.

Section I. REPAIR PARTS; SPECIAL TOOLS; TEST, MEASUREMENT, AND  
DIAGNOSTIC EQUIPMENT (TMDE) ; AND SUPPORT EQUIPMENT

	Para	Page
Common Tools and Equipment . . . . .	3-1	3-2
Special Tools, TMDE, and Support . . . . .	3-2	3-2
Repair Parts . . . . .	3-3	3-2

3-1. COMMON TOOLS AND EQUIPMENT 3-1

For authorized common tools and equipment, refer to the Modified Table of organization and Equipment (MTOE) applicable to your unit.

3-2. SPECIAL TOOLS, TMDE, AND SUPPRT EQUIPMENT 3-2

For authorized special tools and support equipment pertaining to direct support maintenance, refer to TM 11-6625-3081-23P, Repair Parts and Special Tools List (RPSTL). For some work on the EETF TADS/PNVS Augmentation Equipment, special tools, TMDE, or support equipment are needed. The following is a list of these items.

Item No.	National Stock No. <b>or</b> Part No.	Nomenclature
1	AN/USM-451	Multimeter, digital

3-3. REPAIR PARTS 3-3

Repair parts are listed and illustrated in the RPSTL (TM 11-6625-3081-23P) covering organizational and direct support maintenance for this equipment.