

**TECHNICAL MANUAL**

---

**AVIATION INTERMEDIATE MAINTENANCE MANUAL  
UNITS UNDER TEST  
FOR  
TARGET ACQUISITION DESIGNATION SIGHT (TADS) ASSEMBLY  
NIGHT SENSOR ASSEMBLY  
DAY SENSOR SUBASSEMBLY  
CONTROL PANEL ASSEMBLY  
INDIRECT VIEW DISPLAY ELECTRONICS ASSEMBLY  
SOLID STATE CAMERA ASSEMBLY-TADS FLIR, DAY TV  
TELEVISION SENSOR ASSEMBLY  
VISUAL MULTIPLEXER ASSEMBLY  
AND  
PILOT NIGHT VISION SENSOR (PNVS) ASSEMBLY  
NIGHT SENSOR ASSEMBLY  
SOLID STATE CAMERA ASSEMBLY-PNVS  
VISUAL RELAY/MULTIPLEXER ASSEMBLY**

\*This manual supersedes TM 9-6625-476-30 dated 1 December 1987; including all changes.

**DISTRIBUTION STATEMENT A:** "Approved for public release; distribution is unlimited."

**AH-64A ATTACK HELICOPTER**

---

**HEADQUARTERS, DEPARTMENT OF THE ARMY  
21 AUGUST 2001**

TECHNICAL MANUAL

No. 1-6625-476-30

HEADQUARTERS  
DEPARTMENT OF THE ARMY  
WASHINGTON, D.C., 21 AUGUST 2001

TECHNICAL MANUAL  
AVIATION INTERMEDIATE MAINTENANCE MANUAL  
UNITS UNDER TEST  
FOR  
TARGET ACQUISITION DESIGNATION SIGHT (TADS) ASSEMBLY  
NIGHT SENSOR ASSEMBLY  
DAY SENSOR ASSEMBLY  
CONTROL PANEL ASSEMBLY  
INDIRECT VIEW DISPLAY ELECTRONICS ASSEMBLY  
SOLID STATE CAMERA ASSEMBLY-TADS FLIR, DAY TV  
TELEVISION SENSOR ASSEMBLY  
VISUAL MULTIPLEXER ASSEMBLY  
AND  
PILOT NIGHT VISION SENSOR (PNVS) ASSEMBLY  
NIGHT SENSOR ASSEMBLY  
SOLID STATE CAMERA ASSEMBLY-PNVS  
VISUAL RELAY/MULTIPLEXER ASSEMBLY  
AH-64A ATTACK HELICOPTER

REPORTING ERRORS AND RECOMMENDING IMPROVEMENTS  
You can help improve this manual. If you find any errors or if you know of a way to improve the procedures, please let us know. Mail your letter, DA Form 2028 (Recommended Changes to Publications and Blank Forms) or DA Form 2028-2 located in the back of this manual directly to: Commander, U.S. Army Aviation and Missile Command, ATTN: AMSAM-MMC-MA-NP, Redstone Arsenal, AL 35898-5000. A reply will be furnished to you. You may also send in your comments electronically to our e-mail address: [2028@redstone.army.mil](mailto:2028@redstone.army.mil) or FAX us at (256) 842-6546/DSN 788-6546. Instructions for sending an electronic 2028 may be found at the end of this TM immediately preceding the hard copy 2028.

\*This manual supersedes TM 9-6625-476-30, dated 1 December 1987, including all changes.  
Distribution Statement A: Approved for public release; distribution is unlimited.

	Page
HOW TO USE THIS MANUAL.....	iii
CHAPTER 1. INTRODUCTION .....	1-1
CHAPTER 2. TADS NIGHT SENSOR ASSEMBLY .....	2-1
Section I. Preparation for Test.....	2-1
II. Description of Test.....	2-2
III. Test Prompted Procedures.....	2-6
IV. Test Prompted References.....	2-40

TABLE OF CONTENTS - continued

CHAPTER 3.	PNVS NIGHT SENSOR ASSEMBLY .....	3-1
Section I.	Preparation for Test.....	3-1
II.	Description of Test.....	3-3
III.	Test Prompted Procedures.....	3-7
IV.	Test Prompted References.....	3-39
CHAPTER 4.	DAY SENSOR SUBASSEMBLY .....	4-1
Section I.	Preparation for Test.....	4-1
II.	Description of Test.....	4-3
III.	Test Prompted Procedures.....	4-5
IV.	Test Prompted References.....	4-19
CHAPTER 5.	CONTROL PANEL ASSEMBLY .....	5-1
Section I.	Preparation for Test.....	5-1
II.	Description of Test.....	5-2
III.	Test Prompted Procedures.....	5-4
IV.	Test Prompted References.....	5-6
CHAPTER 6.	INDIRECT VIEW DISPLAY ELECTRONICS ASSEMBLY .....	6-1
Section I.	Preparation for Test.....	6-1
II.	Description of Test.....	6-2
III.	Test Prompted Procedures.....	6-4
IV.	Test Prompted References.....	6-4
CHAPTER 7.	TELEVISION SENSOR ASSEMBLY, VISUAL MULTIPLEXER ASSEMBLY, VISUAL RELAY/MULTIPLEXER ASSEMBLY, AND SOLID STATE CAMERA ASSEMBLY (TADS FLIR, PNVS, AND DAY TV) .....	7-1
Section I.	Preparation for Test.....	7-1
II.	Description of Test.....	7-5
III.	Test Prompted Procedures.....	7-10
IV.	Test Prompted References.....	7-14
APPENDIX A.	REFERENCES.....	A-1
APPENDIX B.	UUT/TPS/INTERFACE DEVICE EQUIPMENT MATRIX .....	B-1
GLOSSARY	.....	Glossary-1
INDEX	.....	Index-1

## LIST OF ILLUSTRATIONS

Figure	Title	Page
1-1	Units Under Test.....	1-2
2-1	TADS Night Sensor Assembly .....	2-2
2-2	Insert/Adapter and Alinement Tool Mounted to Sensor Mount Assembly .....	2-7
2-3	Telescope, Reticle, and Target .....	2-8
2-4	X and Y Displacement Measurement Example.....	2-9
2-5	Pneumatic Control Panel .....	2-11
2-6	Toggle and Bleed/Drain Valve Locations.....	2-12
2-7	Inner Case Removal from Shipping and Storage Container .....	2-14
2-8	UUT Handling Fixture Preparation .....	2-16
2-9	Attachment of Handling Fixture to TADS NSA .....	2-17
2-10	Container Base Assembly removal from TADS NSA .....	2-19
2-11	Inner Case Installation in Shipping and Storage Container.....	2-20
2-12	Mounting Insert/Adapter to TADS NSA .....	2-21
2-13	Handling Fixture Removal.....	2-23
2-14	Mounting TADS NSA and Insert/Adapter to Nightside Test Bench .....	2-24
2-15	Pneumatic Control Panel .....	2-25
2-16	Toggle Valve Location .....	2-26
2-17	Gage Locations .....	2-26
2-18	Bleed/Drain Valve Location .....	2-27
2-19	Sensor Mount Handle Location.....	2-29
2-20	Insert/Adapter Removal from TADS NSA .....	2-30
2-21	Mounting Channel Balance Adapter to TADS NSA.....	2-31
2-22	Mounting TADS NSA/Channel Balance Adapter to Sensor Mount Assembly .....	2-31
2-23	Channel Balance Adapter Removal from TADS NSA .....	2-31
2-24	Inner Case Removal from Shipping and Storage Container .....	2-36
2-25	Mounting Base Assembly to TADS NSA.....	2-37
2-26	TADS NSA Atop Workbench with Base Assembly installed.....	2-38
2-27	Handling Fixture Removal.....	2-39
2-28	Inner Case Installation in Shipping and Storage Container.....	2-40
2-29	TADS Night Sensor Assembly (Sheet 1 of 2).....	2-41
2-29	TADS Night Sensor Assembly (Sheet 2 of 2).....	2-42

LIST OF ILLUSTRATIONS - continued

Figure	Title	Page
2-30	Video Post Amplifier-Control Driver CCA Location and Layout .....	2-43
2-31	Video Post Amplifier-Control Driver CCA Channel Locations .....	2-44
2-32	Focus Adjust Pot CCA (A37) Location .....	2-45
2-33	Mask Assembly Installation .....	2-46
2-34	IR Imager Adjustment .....	2-47
2-35	Imager Assembly Adjustment (Sheet 1 of 2) .....	2-48
2-35	Imager Assembly Adjustment (Sheet 2 of 2) .....	2-49
2-36	Connector P9 and Focusing Assembly Locations .....	2-50
2-37	Focus Control CCA Location .....	2-51
2-38	Visual Collimator Location for Boresight Adjustment .....	2-52
2-39	Dead Channel Identification .....	2-53
2-40	Channel Balance Adjustment Waveform .....	2-53
2-41	Boresight Target .....	2-54
2-42	Channel Balance Knob Location .....	2-55
2-43	Wide Field of View Narcissus Pattern .....	2-56
2-44	Medium Field of View Narcissus Pattern .....	2-57
2-45	Narrow Field of View Narcissus Pattern .....	2-58
2-46	OIA Focus Adjustment .....	2-59
2-47	Driver CCA Location .....	2-60
2-48	OIA Boresight Adjustment .....	2-61
2-49	OIA Rotation Adjustment .....	2-62
3-1	PNVS Night Sensor Assembly .....	3-2
3-2	Insert/Adapter and Alinement Tool Assembly Mounting to Sensor Mount Assembly ...	3-8
3-3	Telescope, Reticle, and Target .....	3-9
3-4	X and Y Displacement Measurement Example .....	3-10
3-5	PNVS Holding Fixture and Shipping and Storage Container .....	3-13
3-6	PNVS Turret Installation on PNVS Holding Fixture .....	3-14
3-7	Rim Clenching Clamp Removal from PNVS Turret .....	3-15
3-8	Shroud Assembly Tilting Prior to Removal from PNVS NSA .....	3-16
3-9	Shroud Cable Connector P1 Removal from PNVS NSA .....	3-16
3-10	Interface Structure Insert Mask and Window Assembly Removal .....	3-18

## LIST OF ILLUSTRATIONS - continued

Figure	Title	Page
3-11	PNVS NSA Removal from PNVS Turret Holding Fixture .....	3-18
3-12	Interface Structure Insert Installation on PNVS NSA .....	3-19
3-13	Pneumatic Control Panel .....	3-20
3-14	Toggle and Bleed/Drain Valve Locations.....	3-21
3-15	Mounting of PNVS NSA to Nightside Test Bench (sheet 1 of 2) .....	3-23
3-15	Mounting of PNVS NSA to Nightside Test Bench (sheet 2 of 2) .....	3-24
3-16	Pneumatic Control Panel .....	3-25
3-17	Toggle Valve Location .....	3-26
3-18	Gage Locations .....	3-27
3-19	Bleed/Drain Valve Location .....	3-27
3-20	PNVS NSA Removal from Nightside Test Bench.....	3-29
3-21	Removal of Interface Structure Insert from PNVS NSA .....	3-31
3-22	Mounting of PNVS NSA on PNVS Turret Holding Fixture.....	3-32
3-23	Mirror and Vertical Line or Groove Locations.....	3-33
3-24	Shroud Tilting Prior to Installation on PNVS NSA .....	3-34
3-25	Shroud Cable Connector P1 Installation on PNVS NSA.....	3-35
3-26	Shroud Alinement with PNVS NSA Mounting Base .....	3-36
3-27	Shipping and Storage Container Lid Removal .....	3-37
3-28	PNVS Turret Removal from PNVS Holding Fixture.....	3-38
3-29	PNVS Turret Installation in Shipping and Storage Container .....	3-38
3-30	PNVS Night Sensor Assembly Locational View.....	3-40
3-31	Post Amplifier Control Driver CCA Component Locations .....	3-41
3-32	Post Amplifier Control Driver CCA Channel Locations .....	3-32
3-33	Automatic Control Module CCA Component Locations .....	3-43
3-34	Boresight CCA Component Locations .....	3-44
3-35	Focus Control Adjustment Location .....	3-45
3-36	IR Imager Adjustment Location (sheet 1 of 2).....	3-46
3-36	IR Imager Adjustment Location (sheet 2 of 2).....	3-47
3-37	Visual Relay Focus Adjustment (sheet 1 of 2) .....	3-48
3-37	Visual Relay Focus Adjustment (sheet 2 of 2) .....	3-49
3-38	Boresight Target.....	3-50

LIST OF ILLUSTRATIONS - continued

Figure	Title	Page
3-39	Correct Adjustment of Boresight Target .....	3-51
3-40	Dead Channel Identification Examples .....	3-52
3-41	Channel Balance Adjustment Waveform .....	3-52
3-42	Visual Relay/Multiplexer, Controller CCA, and Test Point Locations .....	3-53
3-43	SIT Target .....	3-54
3-44	MTF Target .....	3-55
3-45	Targets for Beam Saturation Test.....	3-56
4-1	Day Sensor Subassembly.....	4-2
4-2	Inner Case Removal from Shipping and Storage Container .....	4-7
4-3	Day Sensor Subassembly Removal from Base Assembly .....	4-9
4-4	Mounting of Insert/Adapter to Day Sensor Subassembly .....	4-10
4-5	Mounting of Day Sensor Subassembly and Insert/Adapter to Sensor Mount Assembly .....	4-11
4-6	Reassembly of Shipping and Storage Container .....	4-12
4-7	Inner Case Removal from Shipping and Storage Container .....	4-14
4-8	Day Sensor Subassembly Removal from Dayside Test Bench .....	4-16
4-9	Installation of Day Sensor Subassembly in Shipping and Storage Container.....	4-18
4-10	Day Sensor Subassembly Locational Diagram.....	4-20
4-11	24 Power Transit Level Setup .....	4-21
4-12	NFOV Path Accept Criteria .....	4-22
4-13	NFOV Path Reject Criteria .....	4-23
4-14	WFOV Path Accept Criteria .....	4-24
4-15	WFOV Path Reject Criteria .....	4-25
4-16	Resolution Target.....	4-26
4-17	DVO Spiral Reticle Alinement.....	4-27
5-1	Control Panel Assembly.....	5-2
5-2	Control Panel Assembly Removal from Shipping and Storage Container .....	5-5
5-3	Control Panel Assembly Installation into Shipping and Storage Container.....	5-6
5-4	Control Panel Assembly Installation .....	5-7
5-5	Dayside Sensor Mount Assembly Support Hole Locations.....	5-8

## LIST OF ILLUSTRATIONS - continued

Figure	Title	Page
5-6	Optical Alinement Assembly Installation (Sheet 1 of 2) .....	5-9
5-6	Optical Alinement Assembly Installation (Sheet 2 of 2) .....	5-10
5-7	Optical Alinement Assembly Installed Position .....	5-11
5-8	Control Panel Assembly Installed in Control Panel Test Position (Left Mounting Holes) .....	5-12
5-9	Control Panel Assembly Installed in Electrical Test and Alinement Position (Right Mounting Holes) .....	5-13
5-9	Control Panel Assembly Cable Installation .....	5-14
5-11	Optical Alinement Assembly (Without Power Pod Installed) .....	5-15
5-12	Power Pod Assembly (Microscope) Adjustment Locations .....	5-16
5-13	Optical Alinement Assembly (Rear View) .....	5-17
5-14	Optical Alinement Assembly CRT Controls .....	5-18
5-15	Control Panel Assembly Adjustment Tools .....	5-23
5-16	Control Panel Assembly Top Cover .....	5-20
5-17	Control Panel Assembly Adjustment Potentiometer Locations .....	5-21
5-18	Control Panel Assembly Connector J1 and J2 Locations .....	5-22
5-19	Control Panel Assembly Connectors P1 and P2 Locations .....	5-23
5-20	Control Panel Assembly Night Filter Location .....	5-24
5-21	Control Panel Assembly Boresight Control Locations .....	5-25
5-22	Control Panel Assembly with Adjustment Cover Installed .....	5-26
5-23	Control Panel Assembly with Mounting Bracket and Adjustment Cover Installed .....	5-27
5-24	Mounting Bracket (Focus Motor) Assembly .....	5-28
5-25	Control Panel Assembly and Attaching Focus Motor Mounting Bracket Assembly .....	5-29
5-26	Control Panel Assembly Installation into Focus Motor Mounting Bracket Assembly .....	5-30
5-27	Control Panel Assembly Installed in Focus Motor Mounting Bracket in Proper Position for Cable Installation .....	5-31
5-28	Control Panel Assembly CRT Yoke Alinement Locations .....	5-32
5-29	Control Panel Assembly CRT Yoke Alinement Rings Adjustment .....	5-33
5-30	Proper Installation of Reticle Assembly onto CRT Screen .....	5-34
5-31	Control Panel Assembly Reticle Installation .....	5-35
5-32	Control Panel Assembly Mounting Brackets .....	5-36



## LIST OF ILLUSTRATIONS - continued

Figure	Title	Page
5-33	Control Panel Assembly Adjustment Cover Assembly 13073117.....	5-37
5-34	Control Panel Assembly Protective Cover Assembly 13231400 .....	5-38
5-35	Optical Signal Analyzer Door Locations.....	5-39
5-36	Optical Signal Analyzer Bracket Mounting Positions .....	5-40
5-37	Mounting Bracket Assembly (IVD/HDD) Installed.....	5-41
5-38	Mounting Bracket Assembly (Focus Motor) in Installed Position .....	5-42
5-39	Mounting Bracket Assembly (Focus Motor) and Control Panel Assembly Properly Installed.....	5-43
5-40	Optical Signal Analyzer High Voltage Cable Termination (W13 13081942).....	5-44
5-41	Illuminator Source I-250 Installed on Optical Signal Analyzer Door .....	5-45
5-42	Reticle Pattern Descriptions.....	5-46
5-43	Reticle Pattern Dimensions.....	5-47
5-44	Control Panel Assembly CRT Gray Scale Display.....	5-48
5-45	Control Panel Assembly CRT Vertical Bar Display (In Focus).....	5-49
5-46	Control Panel Assembly CRT Vertical Bar Display (Out of Focus) .....	5-49
5-47	Control Panel Assembly CRT Display, 525 Line Rate - Size Box Example .....	5-50
5-48	Control Panel Assembly Display, 525 Line Rate -Horizontal Left Shift .....	5-51
5-49	Control Panel Assembly CRT Display, Horizontal Size Adjustment - In Alinement .....	5-52
5-50	Control Panel Assembly CRT Display, Horizontal Size Adjustment - Out of Alinement (875 Line Rate).....	5-53
5-51	Control Panel Assembly CRT Display, Vertical Size Prelinement Box (875 Line Rate).....	5-54
5-52	Control Panel Assembly CRT Display, Vertical Size Adjustment - In Alinement (875 Line Rate).....	5-55
5-53	Control Panel Assembly CRT Display, Vertical Size Adjustment - Out of Alinement (875 Line Rate).....	5-56
5-54	Control Panel Assembly CRT Display, Centering Test - Horizontal Error .....	5-57
5-55	Control Panel Assembly CRT Display, Vertically and Horizontally Off-Center .....	5-58
5-56	Control Panel Assembly CRT Display, Rotation Test.....	5-59
5-57	Control Panel Assembly CRT Display, Rotation Error .....	5-60
5-58	Control Panel Assembly CRT Display, Linearity Test - Crosshatch Adjustment .....	5-61
5-59	Control Panel Assembly CRT, Display, Linearity Examples.....	5-62

## LIST OF ILLUSTRATIONS - continued

Figure	Title	Page
5-60	Control Panel Assembly CRT Display, Window Display .....	5-63
5-61	Control Panel Assembly CRT Display, Linearity Examples.....	5-64
5-62	Proper Installation of Current Probe.....	5-65
5-63	Optical Signal Analyzer Panel.....	5-66
6-1	IVD Electronics Assembly .....	6-2
6-2	IVD Electronics Assembly Removal from Shipping and Storage Container.....	6-5
6-3	IVD Electronics Assembly Installation into Shipping and Storage Container .....	6-7
6-4	IVD Electronics Assembly Installation.....	6-9
6-5	Optical Alinement Assembly (Without Power Pod Installed).....	6-10
6-6	Optical Alinement Assembly (Rear View) .....	6-11
6-7	Dayside Sensor Mount Assembly Support Hole Locations.....	6-12
6-8	Optical Alinement Assembly Installation .....	6-13
6-9	IVD Electronics Assembly Bottom Cover .....	6-14
6-10	IVD Electronics Assembly Component Locations .....	6-15
6-11	IVD Electronics Assembly Top Cover.....	6-16
6-12	IVD Electronics Assembly Component Locations .....	6-17
6-13	Upper and Lower IVD Protective Cover Assemblies.....	6-18
6-14	IVD Electronics Assembly With Upper IVD Protective Cover Assembly Installed .....	6-19
6-15	IVD Electronics Assembly With Lower IVD Protective Cover Assembly Installed .....	6-20
6-16	IVD Electronics Assembly Installation Support Points .....	6-21
6-17	IVD Electronics Assembly Installation (Forward View).....	6-22
6-18	IVD Electronics Assembly Installation (Rear View) .....	6-23
6-19	IVD Electronics Assembly Installed on Optical Alinement Assembly.....	6-24
6-20	Optical Alinement Assembly CRT Controls.....	6-25
6-21	Power Pod Assembly (Microscope) Adjustment Locations.....	6-26
6-22	Optical Signal Analyzer Door Locations.....	6-27
6-23	IVD Electronics Assembly OSA Connector View .....	6-28
6-24	OSA IVD Electronics Assembly Mounting Bracket Positions.....	6-29
6-25	IVD Electronics Assembly Properly Installed .....	6-30
6-26	IVD Electronics Assembly Yoke Alinement Locations.....	6-31
6-27	IVD Electronics Assembly Reticle Installation.....	6-32

LIST OF ILLUSTRATIONS - continued

Figure	Title	Page
6-28	Reticle Pattern Descriptions.....	6-33
6-29	Reticle Pattern Dimensions.....	6-34
6-30	IVD Electronics Assembly CRT Display - Vertical Hold Problem.....	6-34
6-31	IVD Electronics Assembly CRT Display - Horizontal Hold Problem.....	6-35
6-32	IVD Electronics Assembly CRT Display - Horizontal Skewing Problem .....	6-35
6-33	IVD Electronics Assembly CRT Display - Horizontal and Vertical Hold Problem.....	6-36
6-34	IVD Electronics Assembly CRT Display - Gray Scale.....	6-36
6-35	IVD Electronics Assembly CRT Display - Magnified Raster Scan Lines - In Focus.....	6-37
6-36	IVD Electronics Assembly CRT Display - Magnified Raster Scan Lines - Out of Focus .....	6-38
6-37	IVD Electronics Assembly CRT Display - Small Window With 0 Percent Error .....	6-39
6-38	IVD Electronics Assembly CRT Display - Small Window With 2 Percent Size Error ....	6-39
6-39	IVD Electronics Assembly CRT Display - Small Window With 4 Percent Size Error ....	6-40
6-40	IVD Electronics Assembly CRT Display - Nominal Alinement of Horizontal Interactive Alinement Pattern .....	6-40
6-41	IVD Electronics Assembly CRT Display - Slight Misalinement of Horizontal Interactive Alinement Pattern .....	6-41
6-42	IVD Electronics Assembly CRT Display - Gross Misalinement of Horizontal Interactive Alinement Pattern .....	6-41
6-43	IVD Electronics Assembly CRT Display - 0 Percent Size Error - Fullscreen (875 Line Rate) .....	6-42
6-44	IVD Electronics Assembly CRT Display - 5 Percent Error - Fullscreen (875 Line Rate) .....	6-42
6-45	IVD Electronics Assembly CRT Display - Nominal Distortion Alinement.....	6-43
6-46	IVD Electronics Assembly CRT Display - Out of Tolerance Distortion Alinement Example.....	6-43
6-47	IVD Electronics Assembly CRT Display - Nominal Centering Alinement.....	6-44
6-48	IVD Electronics Assembly CRT Display - Centering Misalinement Example.....	6-44
6-49	IVD Electronics Assembly CRT Display - Nominal Rotation Alinement.....	6-45
6-50	IVD Electronics Assembly CRT Display - Rotation Misalinement Example .....	6-46
6-51	Illuminator Source I-250 Installed on OSA Door .....	6-47

## LIST OF ILLUSTRATIONS - continued

Figure	Title	Page
6-52	OSA Bracket Mounting Positions .....	6-48
6-53	Mounting Bracket Assembly (IVD/HDD) Installed .....	6-49
6-54	Mounting Bracket Assembly (Focus Motor) in Installed Position .....	6-50
6-55	Spotmeter Installation (OSA Calibration) .....	6-51
6-56	IVD Electronics Assembly Adjustment Tools.....	6-52
6-57	IVD Electronics Assembly CEM CCA Locations .....	6-53
6-58	IVD Electronics Assembly Yoke Alinement Rings .....	6-54
6-59	High Voltage Adjustment Pot Location (OSA Calibration).....	6-55
6-60	Top and Bottom Alinement Cover Assemblies (Internal HDD Calibration).....	6-56
6-61	Bottom Alinement Cover Installed (Internal HDD Calibration) .....	6-57
6-62	IVD Electronics Assembly Adjustment Component Locations (Bottom) (Internal HDD Calibration) .....	6-58
6-63	Top Alinement Cover Installed (Internal HDD Calibration) .....	6-59
6-64	IVD Electronics Assembly Adjustment Component Locations (Top) (Internal HDD Calibration) .....	6-60
6-65	IVD Electronics Assembly CEM CCA Adjustment Locations .....	6-61
7-1	Television Sensor Assembly, Visual Multiplexer Assembly and Visual Relay/Multiplexer Assembly .....	7-3
7-2	Camera Assemblies, Solid State (TADS FLIR, PNVs, and DAY TV).....	7-4
7-3	Television Sensor Assembly or Solid State Camera Removal from Shipping and Storage Container .....	7-11
7-4	Television Sensor Assembly or Solid State Camera Installation into Shipping and Storage Container .....	7-13
7-5	Television Sensor Assembly Physical Configuration.....	7-15
7-6	Solid State Camera Assembly - DAY TV Physical Configuration .....	7-16
7-7	TADS Visual Multiplexer and PNVs Relay/Multiplexer Assemblies Physical Configuration .....	7-17
7-8	Solid State Camera Assemblies (TADS FLIR and PNVs) - Physical Configuration .....	7-18
7-9	Electro-Optical Bench Configuration for Testing .....	7-19
7-10	Optical Signal Generator Assembly .....	7-20
7-11	Television Sensor Assy or Solid State Camera Assy - DAY TV (not shown) Mounted to Optical Signal Generator Image Port.....	7-21

LIST OF ILLUSTRATIONS - continued

Figure	Title	Page
7-12	PNVS Visual Relay/Multiplexer or Solid State Camera Assy - (not shown) Mounted to Optical Signal Generator Collimator Port .....	7-22
7-13	TADS Visual Multiplexer or Solid State Camera Assy - TADS FLIR (not shown) Mounted to Optical Signal Generator Collimator Port .....	7-23
7-14	Optical Alinement Assembly Mounting Location.....	7-24
7-15	Optical Alinement Assembly Installation .....	7-25
7-16	Monitor Shelf Assembly Mounting .....	7-26
7-17	Oscilloscope Shelf Assembly Mounting .....	7-27
7-18	Terminal Box/Television Monitor Interface .....	7-28
7-19	Portable Monitor Location for Geometric Distortion Test .....	7-29
7-20	Television Sensor Assy or Solid State Camera Assy - DAY TV Adapter Plate Assembly.....	7-30
7-21	Optical Signal Generator Shading Port.....	7-31
7-22	Television Sensor Assy or Solid State Camera Assy - DAY TV (not shown) Mounted to Shading Port.....	7-32
7-23	PNVS Visual Relay/Multiplexer or Solid State Camera Assy - PNVS (not shown) Mounted to Optical Signal Generator Shading Port .....	7-33
7-24	TADS Visual Multiplexer or Solid State Camera Assy - TADS FLIR (not shown) Mounted to Optical Signal Generator Shading Port .....	7-34
7-25	Displayed 10 Shades of Gray .....	7-35
7-26	Displayed 10 Mhz Burst Pattern .....	7-35
7-27	Monitor Underscan Raster .....	7-36
7-28	Television Sensor, Visual Multiplexer, and Visual Relay/Multiplexer Assemblies Pot Locations.....	7-37
7-29	Displayed Test Chart (Four Scan Modes) .....	7-38
7-30	Television Sensor, Visual Multiplexer, and Visual Relay/Multiplexer Assemblies Alinement Factors.....	7-39
7-31	UUT Assembly/Solid State Camera .....	7-40
7-32	Camera Tube Rotation With Spanner Wrench.....	7-41
7-33	Vidicon Rotation Adjustment.....	7-42
7-34	Solid State Camera Boresight Rotation Alinement .....	7-43

## LIST OF ILLUSTRATIONS - continued

Figure	Title	Page
7-35	Raster Translation Alinement.....	7-44
7-36	Raster Rotation Alinement.....	7-45
7-37	Raster Rotation Marker Alinement.....	7-46
7-38	Displayed Resolution Bar Location.....	7-47
7-39	Prealignment Coarse Boresight Marker Alinement.....	7-48
7-40	Discharge Non-Uniformity Illustration.....	7-49
7-41	Prealignment Raster Size/Centering Marker Alinement.....	7-50
7-42	Prealignment Full Scan Horizontal Size Marker Alinement.....	7-51
7-43	Prealignment Boresight Marker Alinement.....	7-52
7-44	Prealignment Underscan Size/Centering Marker Alinement.....	7-53
7-45	UUT Alinement Tools.....	7-54
7-46	Multiplexer (Without Lens) Mounted to Optical Signal Generator Image Port.....	7-55
7-47	Line Select Marker Location (Signal Amplifier/SNR Test).....	7-56
7-48	Line Select Marker Location (CTF Test).....	7-57
7-49	Line Select Marker Location (CTF Signal Uniformity Test).....	7-58
7-50	Line Select Marker Location (Peaking Test).....	7-59
7-51	Video Peaking Waveforms.....	7-60
7-52	Video Waveform (Video Amplitude/SNR Test).....	7-61
7-53	Video Waveform (Normal Scan CTF Test).....	7-62
7-54	Video Waveform (Reverse Scan CTF Test).....	7-63
7-55	Parabolic Shading Adjustment for CTF Measurement.....	7-64
7-56	Ramp Shading Adjustment for CTF Measurement (Normal Scan).....	7-65
7-57	Ramp Shading Adjustment for CTF Measurement (Reverse Scan).....	7-66
7-58	Parabola Shading Adjustment for CTF Measurement (Reverse Scan).....	7-67
7-59	PNVS Visual Relay/Multiplexer (Vidicon) Optical Focus.....	7-68
7-60	PNVS Visual Relay/Multiplexer (Solid State Camera) Optical Focus.....	7-69
7-61	TADS Visual Multiplexer Optical Focus.....	7-70
7-62	Temperature Controller Potentiometer Location.....	7-71
7-63	Full Scan Horizontal Size Marker Alinement.....	7-72
7-64	Underscan Horizontal Size Marker Alinement.....	7-73
7-65	Vertical Size Marker Alinement.....	7-74

LIST OF ILLUSTRATIONS - continued

Figure	Title	Page
7-66	Boresight Marker Alinement (Normal Full Scan).....	7-75
7-67	Boresight Marker Alinement (Reverse Full Scan).....	7-76
7-68	Boresight Marker Alinement (Normal Underscan).....	7-77
7-69	Boresight Marker Alinement (Reverse Underscan).....	7-78
7-70	Crosshatch Pattern Setup.....	7-79
7-71	Geometric Distortion Measurement.....	7-80
7-72	Capacitor Load Self-Test Connector.....	7-81
7-73	Horizontal Parabola Shading Adjustment.....	7-82
7-74	Horizontal Ramp shading Adjustment.....	7-83
7-75	Vertical Parabola Shading Adjustment.....	7-84
7-76	Vertical Ramp Shading Adjustment.....	7-85
7-77	Blemish Definition.....	7-86
7-78	Marker Positioning Procedure.....	7-87
7-79	Marker Positioning Criteria.....	7-88
7-80	Flat Video Waveform.....	7-89
7-81	Trim Capacitor Adjustment (Coarse).....	7-90
7-82	Trim Capacitor Adjustment (Fine).....	7-91
7-83	H Cathode Blanking Delay Adjustment.....	7-92
7-84	Temperature Controller Disassembly/Reassembly.....	7-93
7-85	UUT Cover Removal/Reassembly.....	7-94
7-86	Optical Coupler Mounting.....	7-95
7-87	TV Sensor Mounting and CCA Adjustment.....	7-96
7-88	Raster Orthogonality Adjustment.....	7-97
7-89	Alinement Cover Mounting/Removal.....	7-98
7-90	Multiplexer Mounting (Coarse Alinement).....	7-99

LIST OF TABLES

Table	Title	Page
1-1	Official Nomenclature, Names, and Designations.....	1-3
A-1	References .....	A-1
B-1	UUT/Test Program .....	B-1
B-2	Interface Device Items Required for Testing .....	B-3



## HOW TO USE THIS MANUAL

If you cannot find the information you are looking for, you cannot properly do your job. Take a few minutes to look through this manual. You will find it easier to use once you have become familiar with it.

Each chapter and section is set up to lead you through it step by step. For example:

1. On the chapter page, you will see a listing of the sections in that chapter. Listed under the section titles is a listing of the tasks for that section. Find the task (by title) that you have been assigned. Now, look across from the task title and you will find the paragraph and page number for the task. Notice that the chapter number forms part of the page number.
2. Now that you have located the page number, turn to that page and review the task requirements before starting the procedures.
3. Did you notice that each task or job begins with an initial setup?
  - a. INITIAL SETUP lists the configuration, test equipment, tools and special tools, materials/parts, military occupational specialty (MOS), references, safety instructions, condition equipment should be in, and general instructions for you to complete the task. FOLLOWUP lists the procedures to be performed after you have completed the basic task.
  - b. Now, what exactly does INITIAL SETUP mean to you? The term "INITIAL SETUP" means, "DO THIS FIRST BEFORE STARTING THE TASK." Review one of the initial setup tables and become familiar with the requirements.
4. An explanation of the initial setup headings is presented below.
  - a. Tools and Special Tools. Special tools needed to perform the task. Be sure to acquire all the tools before you start the task.
  - b. Materials/Parts. Materials and parts needed to perform the task. Materials can be found in Appendix C. Next to the name of the material listed in the initial setup you will find an item number. This number matches the item number in column (1) of Appendix C. Be sure to acquire all the materials and parts before you start the task.
  - c. Personnel Required. MOS required to do the task. This will also tell you the number of persons needed to perform the task.
5. You can also use the table of contents on page i of this manual to locate page number for chapters, sections, and the appendixes.
6. Let's see if you understand how to find a specific task. Suppose your supervisor wants you to replace a part or assembly.

Here's how you would find it:

  - a. Obtain the correct TM for the task and look up the procedure in the chapter covering the type of task you are to perform.
  - b. For example: Replacement is a maintenance task you can find located in the maintenance chapter.

## HOW TO USE THIS MANUAL (cont)

- c. Looking at the section titles listed in the maintenance chapter index, you should have located the page number for the maintenance procedures. Going to that page you found the section index and located the paragraph and page number of the replacement task.
7. Another approach would be to look in the alphabetical index in the rear of the manual.

**CHAPTER 1**

**INTRODUCTION**

Subject	Para	Page
Scope.....	1-1	1-1
Maintenance Forms, Records, and Reports .....	1-2	1-1
Official Nomenclature, Names, and Designations .....	1-3	1-3
References.....	1-4	1-3
Effectivity .....	1-5	1-3

**1-1. SCOPE.**

a. Type of Manual. This manual provides aviation intermediate maintenance (AVIM) supplemental testing instructions for certain units under test (UUT) (figure 1-1) that are a part of the Target Acquisition Designation Sight (TADS) Assembly AN/ASQ-170 and the Pilot Night Vision Sensor (PNVS) Assembly AN/AAQ-11 equipment.

b. Equipment Names. The following items of equipment are covered (refer to appendix B for UUT and test program software part numbers):

<u>Equipment</u>	<u>End Item</u>
Night Sensor Assembly	TADS
Night Sensor Assembly	PNVS
Day Sensor Subassembly	TADS
Control Panel Assembly	TADS
Indirect View Display Electronics Assembly	TADS
Camera Assembly, Solid State - Day TV	TADS
Television Sensor Assembly	TADS
Camera Assembly, Solid State - TADS FLIR	TADS
Visual Multiplexer Assembly	TADS
Camera Assembly, Solid State - PNVS	PNVS
Visual Relay/Multiplexer Assembly	PNVS

**1-2. MAINTENANCE FORMS, RECORDS, AND REPORTS.**

Department of the Army forms and procedures used for equipment maintenance will be those prescribed by DA PAM 738-751, The Army Maintenance Management System (TAMMS).

1-2. MAINTENANCE FORMS, RECORDS, AND REPORTS. (CONT)

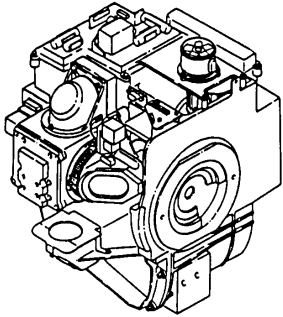

TADS NIGHT SENSOR ASSEMBLY

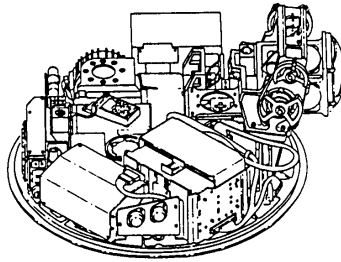

PNVS NIGHT SENSOR ASSEMBLY

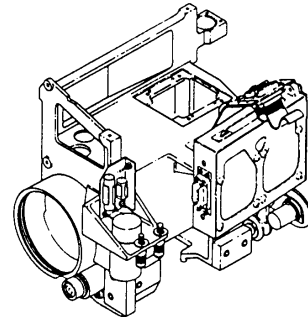

TADS DAY SENSOR SUBASSEMBLY

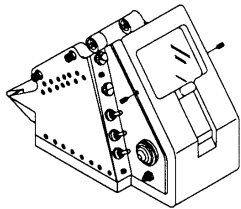

CONTROL PANEL ASSEMBLY

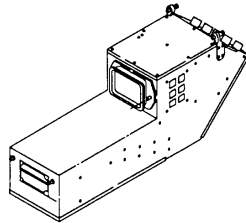

TADS INDIRECT VIEW DISPLAY  
ELECTRONICS ASSEMBLY

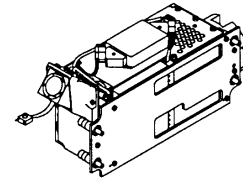

TADS CAMERA ASSEMBLY  
SOLID STATE DAY TV

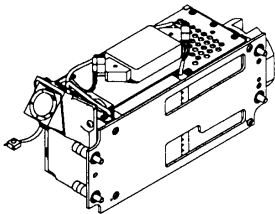

TELEVISION SENSOR ASSEMBLY

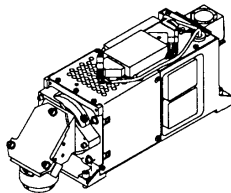

CAMERA ASSEMBLY  
SOLID STATE - TADS FLIR

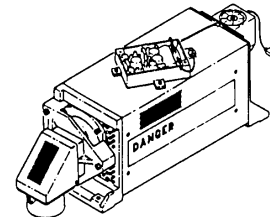

VISUAL MULTIPLEXER  
ASSEMBLY

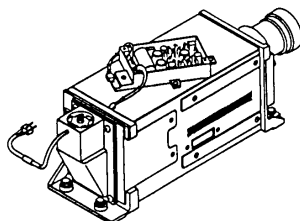

VISUAL RELAY/MULTIPLEXER  
ASSEMBLY

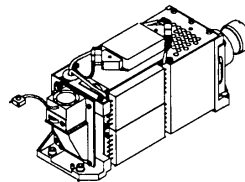

CAMERA ASSEMBLY  
SOLID STATE - PNVS

TP1-771-053B

Figure 1-1. Units Under Test

**1-3. OFFICIAL NOMENCLATURE, NAMES, AND DESIGNATIONS.**

Table 1-1 contains a listing of nomenclature cross-references used in this manual.

**1-4. REFERENCES.**

Refer to appendix A for a listing of all technical data referenced or used in conjunction with this manual.

**1-5. EFFECTIVITY.**

This manual replaces all test program instruction documents that were previously used during UUT testing of the seven covered test program sets.

Table 1-1. Official Nomenclature, Names, and Designations

Common Name	Official Nomenclature
EETF	Electronic Equipment Test Facility
E/O Bench Set	Test Dayside Test Bench 2A1
	Test Console Test Bench 2A2
	Nightside Test Bench 2A3
NSA	Night Sensor Assembly
PNVS	Pilot Night Vision Sensor Assembly
TADS	Target Acquisition Designation Sight Assembly

**CHAPTER 2**

**TADS NIGHT SENSOR ASSEMBLY**

	Section	Page
Preparation for Test .....	I	2-1
Description of Test .....	II	2-2
Test Prompted Procedures .....	III	2-6
Test Prompted References .....	IV	2-40

**Section I. PREPARATION FOR TEST**

Subject	Para	Page
Test Preparation .....	2-1	2-1
UUT Description .....	2-2	2-1
Precautions .....	2-3	2-1

**2-1. TEST PREPARATION.**

No special procedures are required to prepare the TADS Night Sensor Assembly (NSA) for test. Refer to the UUT/TPS/interface device matrix tables in appendix B to determine the correct UUT test program part number for the TADS NSA. Then refer to the UUT test program for a list of cables, test equipment, and test accessories required to test the TADS NSA.

**2-2. UUT DESCRIPTION.**

The TADS NSA (figure 2-1) is a forward looking infrared (FLIR) target imaging and designating assembly that converts IR image scenes into video to be used for target designating and tracking. It contains no operating controls or indicators. All components of the TADS NSA that are referenced during the UUT test are shown in the illustrations in Section IV.

**2-3. PRECAUTIONS.**

The TADS NSA is an electro-mechanical device containing delicate electro-optical components. Use extreme care when handling the TADS NSA to prevent damage to these components. Observe the following general guidelines when lifting or moving it.

- a. Weight. The TADS NSA weighs 55 pounds. Always get help when lifting or moving it.
- b. Optics. Do not touch optics assemblies with your bare hands. Do not use the optics assemblies for any purpose when lifting the TADS NSA. If you accidentally place any pressure or force on the optics assemblies, you could contaminate or damage them, or cause misalignment. Whenever possible, mount the TADS NSA onto its handling fixture when movement is necessary.

**2-3. PRECAUTIONS. (CONT)**

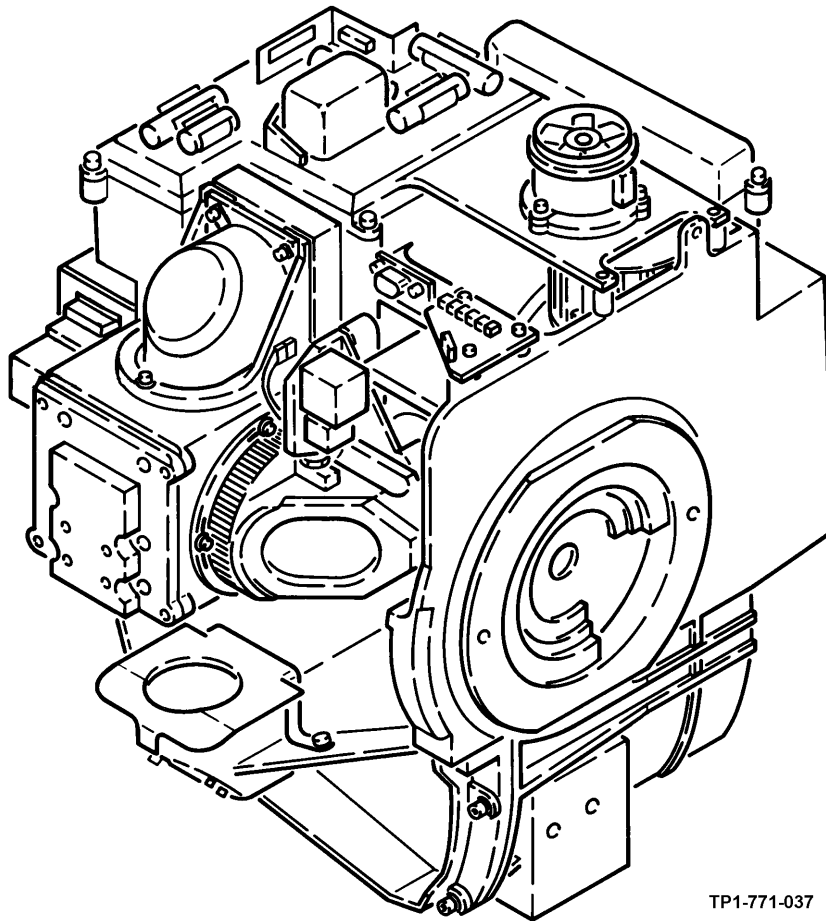

TP1-771-037

Figure 2-1. TADS Night Sensor Assembly

**Section II. DESCRIPTION OF TEST**

Subject	Para	Page
General .....	2-4	2-2
Test Concept .....	2-5	2-3
Test Description .....	2-6	2-3
Pretesting Data .....	2-7	2-5
Final Acceptance .....	2-8	2-6

**2-4. GENERAL.**

This section describes the UUT test for the TADS NSA. It includes an explanation of the way testing is accomplished and a description of the test.